

 CHECK VALVE zCHE



Body material	Nominal pressure	Nominal diameter	Max. temperature
A Grey cast iron	C 16 bar	DN 40-300	300°C
	B 10 bar	DN 40-250	



correspond to the pressure equipment directive 2014/68/UE marking CE for DN≥40

FEATURES

- closing tightness acc. to EN -12334
- compact settlement
- environment-friendly
- no maintenance
- flanges drilled according to EN 1092-2
- face-to-face dimension according to EN 558 series 48

APPLICATION *

* not all of the applications are suitable for all of the executions

industries



INDUSTRY

media



SEWAGE



INDUSTRIAL
WATER



NEUTRAL FLUIDS

Data given can be changed without notice.

Edition 01/2018

MATERIALS, DIMENSIONS

Type 01; 02

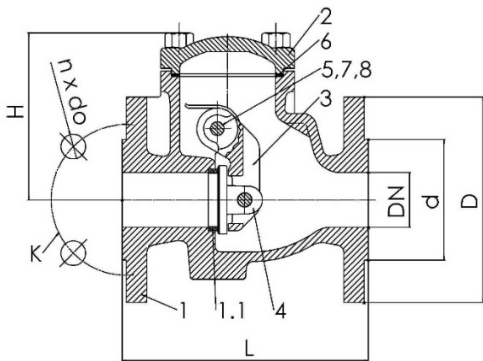

Type 06; 16; 26

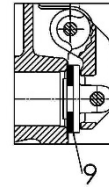

Type 91

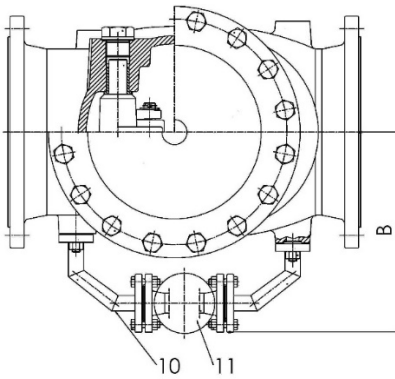

Type 11; 21 ;12; 22

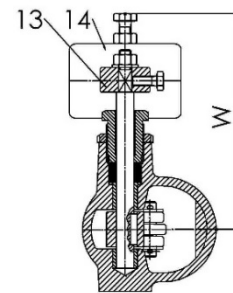
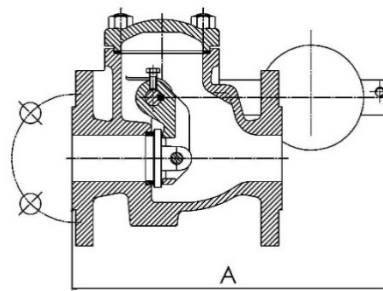

Type 66

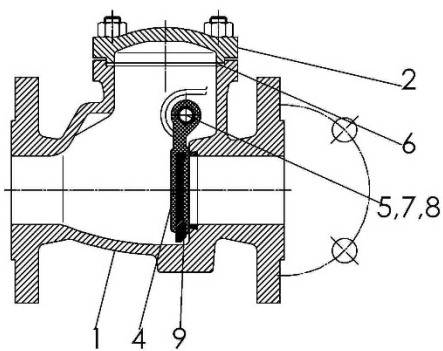

Type 76

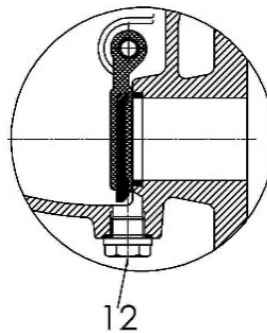

Type 86

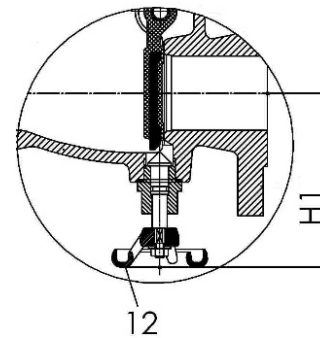

Data given can be changed without notice.

Edition 01/2018

ZETKAMA Sp. z o.o.
Ul. 3 Maja 12
PL 57-410 Ścinawka Średnia

Tel. +48 74 8652 193
Tel. +48 74 8652 111
Fax +48 74 8652 199

E-mail export@zetkama.com.pl
www.zetkama.com

FIG.302

	Body material	A													
		Type	01	02	06	91	11	21	12	22	16	26	66	76	86
1	Body	EN – GJL-250 5.1301 (ex. JL1040)													
1.1	Seat ring	X20Cr13 1.4021	G-CuSn10	-	X20Cr13 1.4021			G-CuSn10			-				
2	Cover	EN – GJL-250 5.1301 (ex. JL1040)													
3	Bow	EN – GJS-500-7 5.3200 (ex. JS1050)										-			
4	Flap	LH14 (G- X20Cr14)	G-CuSn10	EN – GJS- 500-7 5.3200 (ex. JS1050)	LH14 (G-X20Cr14)			G-CuSn10			EN – GJS-500-7 5.3200 (ex. JS1050)		EN – GJS-500-7 +vulcanized EPDM		
5	Flap pin	X20Cr13 1.4021	CuZn40Pb2	X20Cr13 1.4021				CuZn40Pb2			X20Cr13 1.4021				
6	Cover gasket	Graphite CrNi													
7	Plug	10S20 zinc - DN40-150 EN – GJL-250 JL1040 - DN200-300			EN – GJL- 250 5.1301 (ex. JL1040)		-					10S20 Zinc			
8	Plug gasket	Carbomide-rubber				-					Carbomide-rubber				
9	Flap ring	-		EPDM	-			-			EPDM				
10	Pipeline	-			carbon steel		-								
11	By-pass	-			Fig. 215		-								
12	Plug	-										CuZn37	EN – GJL-250 5.1301 (ex. JL1040)		
13	Hinge	-				S235JR					-				
14	Weight	-				EN – GJL-250 5.1301 (ex. JL1040)					-				
Max. temperature		300°C	225°C	120°C	300°C			225°C			120°C				

Data given can be changed without notice.

Edition 01/2018

FIG.302

DN	40	50	65	80	100	125	150	200	250	300
L	180	200	240	260	300	350	400	500	600	700
D	150	165	185	200	220	250	285	340	405	460
d	84	99	118	132	156	184	211	266	319	370
K	110	125	145	160	180	210	240	295	355	410
nxdo	4x19	4x19	4x19	8x19	8x19	8x19	8x23	12x23	12x28	12x28
H	119	120	141	168	175	199	217	292	355	374
A	350	352	359	371	447	466	574	662	800	820
W	170	180	190	200	210	225	250	306	348	348
H1	120	125	130	140	175	190	210	280	315	-
B	-	-	-	-	-	-	-	380	410	400
Weight (kg) type 01, 02	9	11	15,2	20,8	31,5	46	60	120	180	250
Weight (kg) type 11,21 type 12,22	11,8	13,5	18	23,5	36	51	67	129	198	285
Weight (kg) type 86	9	12,6	17	21,9	31	45	61	120	180	-
Weight (kg) type 91	-	-	-	-	-	-	-	131	202	283
K _{vs} (m ³ /h)	46,2	78,2	139,1	207,5	336,8	526,3	756,7	1278	1996	2419,6

PRESSURE-TEMPERATURE RATINGS

Acc. EN 1092-2	PN		-10 ÷120°C	150°C	200°C	250°C	300°C
EN – GJL-250	10	bar	10	9	8	7	6
EN – GJL-250	16		16	14,4	12,8	11,2	9,6

Data given can be changed without notice.

Edition 01/2018

TYPE

Figure	Body material	Nominal diameter	Nominal pressure	Type
302	A Grey cast iron EN-GJL-250	40-300 mm	C 16 bar	flap and seat ring - stainless steel 01
		40-300 mm	C 16 bar	flap and seat ring - bronze 02
		40-300 mm	C 16 bar	flap - nodular cast iron; flap ring EPDM 06
		40-150 mm	C 16 bar	flap and seat ring - stainless steel; counterweight and lever fitted on one side 11
		40-150 mm	C 16 bar	flap and seat ring – bronze; counterweight and lever fitted on one side 12
		40-150 mm	C 16 bar	flap - nodular cast iron; flap ring EPDM; counterweight and lever fitted on one side 16
		200-300 mm	C 16 bar	flap and seat ring - stainless steel; counterweight and lever fitted on both side 21
		200-300 mm	C 16 bar	flap and seat ring – bronze; counterweight and lever fitted on both side 22
		200-300 mm	C 16 bar	flap and seat ring – bronze; counterweight and lever fitted on both side 26
		40-250 mm	B 10 bar	EPDM covered flap 66
		40-250 mm	B 10 bar	EPDM covered flap; closing EPDM/cast iron plug 76
		40-250 mm	B 10 bar	EPDM covered flap; rising pin 86
		200-300 mm	B 10 bar	flap and seat ring - stainless steel by pass 91
		40-300 mm	C 16 bar	flap and seat ring - stainless steel; epoxy paint 01-D
		40-300 mm	C 16 bar	flap - nodular cast iron; flap ring EPDM; epoxy paint 06-D
		40-150 mm	C 16 bar	flap and seat ring - stainless steel; counterweight and lever fitted on one side; epoxy paint 11-D
		40-150 mm	C 16 bar	flap - nodular cast iron; flap ring EPDM; counterweight and lever fitted on one side; epoxy paint 16-D
		200-300 mm	C 16 bar	flap and seat ring - stainless steel; counterweight and lever fitted on both side; epoxy paint 21-D
		200-300 mm	C 16 bar	flap - nodular cast iron; flap ring EPDM; counterweight and lever fitted on both side; epoxy paint 26-D
		40-250 mm	B 10 bar	EPDM covered flap; epoxy paint 66-D
		40-250 mm	B 10 bar	EPDM covered flap; rising pin; epoxy paint 86-D

Data given can be changed without notice.

Edition 01/2018

ORDERING

Figure	Body material	Nominal diameter	Nominal pressure	Type
302	A Grey cast iron EN-GJL-250	40-300 mm	C 16 bar	01 flap and seat ring - stainless steel

Order example acc. index

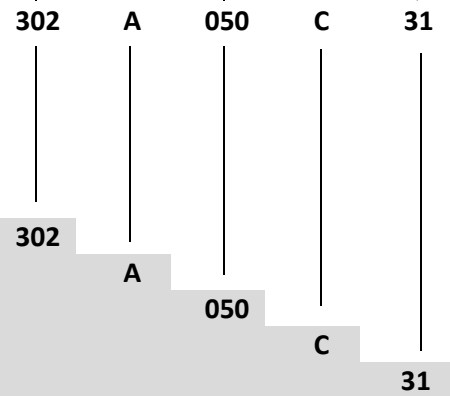

Check valves, ends flanged, form straight
 Grey cast iron EN-GJL-250
 Nominal diameter (mm)
 Nominal pressure PN 16
 Flap and seat ring stainless steel

Data given can be changed without notice.

Edition 01/2018