



Qualität von Anfang an.

## Technische Daten

### BAUFORM

2- teilige Körperkonstruktion (verschraubt)

### ANSCHLUSS

Innengewinde: 1/2" - 3", (DIN ISO 228 T1);  
Innengewinde: 1/2" - 2" NPT (ASME B1 20.1)  
Anschweißenden: DN15 - DN80 nach  
ISO 4200, DIN 11850-2 oder  
DIN 3239 (nur DN15 - DN50)

### EINBAULAGE

Beliebig, Durchflußrichtung beachten.

### MEDIUMDRUCK

max. 40 bar

### ÖFFNUNGSDRUCK

ca. 0,10 bar

### TEMPERATUR

PTFE: -30°C bis max. +140°C  
FKM: -20°C bis max. +140°C  
EPDM: -20°C bis max. +130°C

### WERKSTOFFE

Gehäuse:	Edelstahl	1.4408
Deckel:	Edelstahl	1.4408
metallische Innenteile:	Edelstahl	1.4404
Feder:	Edelstahl	1.4310
Dichtung:	PTFE	
	FKM	
	EPDM	

Alle Angaben sind freibleibend und unverbindlich!

## Specification

### DESIGN

Body consists of two screwed parts

### CONNECTION

Female thread: 1/2" - 3", (DIN ISO 228 T1);  
Female thread: 1/2" - 2" NPT (ASME B1 20.1)  
Welded connection DN15 - DN80 acc. to  
ISO 4200, DIN 11850-2 or  
DIN 3239 (only DN15 - DN50)

### MOUNTING POSITION

As desired, please refer to flow direction.

### PRESSURE RANGE

max. 40 bar

### ACTION PRESSURE

ca. 0,10 bar

### TEMPERATURE RANGE

PTFE: -30°C up to max. +140°C  
FKM: -20°C up to max. +140°C  
EPDM: -20°C up to max. +130°C

### MATERIAL

Body:	Stainless steel	1.4408
Cover:	Stainless steel	1.4408
metallic inner parts:	Stainless steel	1.4404
Spring:	Stainless steel	1.4310
Seal:	PTFE	
	FKM	
	EPDM	

The above information is intended for guidance only and the company reserves the right to change any data herein without prior notice!

Artikel:

**EB**

Rückschlagventil

PN 40

Edelstahl



Type:

**EB**

Non-return valve

PN 40

Stainless steel



**Artikel- u. Bestellangaben: z.B. EB310064/L**

= Rückschlagventil, Edelstahl / PTFE, DN 25 mit Anschweißenden für Rohr nach ISO 4200

1.+ 2. Stelle Produkt	3.+ 4. Stelle Werkstoffe Gehäuse / Dichtung	5. Stelle Betätigung	6. Stelle Optionen	7. - 10. Stelle Anschlußgröße			
EB= Rückschlagventil	31 = Edelstahl / PTFE 33 = Edelstahl / FKM 34 = Edelstahl / EPDM	0 = ohne	0 = ohne	Gewinde			
				ISO228		Anschweißenden DIN EN 3239	
				NPT		62 = DN 15	/L = ISO 4200 /M = DIN 11850-2
				23 = 1/2"	53 = 1/2"	63 = DN 20	
				24 = 3/4"	54 = 3/4"	64 = DN 25	
				25 = 1"	55 = 1"	65 = DN 32	
				26 = 1 1/4"	56 = 1 1/4"	66 = DN 40	
				27 = 1 1/2"	57 = 1 1/2"	67 = DN 50	
				28 = 2"	58 = 2"	68 = DN 65	
				29 = 2 1/2"		69 = DN 80	
				30 = 3"			

**Ordering example: e.G. EB310064/L**

= Non-return valve, stainless steel / PTFE, DN 25 with butt weld (ISO 4200)

1.+ 2. Digit Product	3.+ 4. Digit Material Body / Sealing	5. Digit Operation	6. Digit Options	7. - 10. Digit Connecting size			
EB= Non-return valve	31 = Stainless st. / PTFE 33 = Stainless st. / FKM 34 = Stainless st. / EPDM	0 = without	0 = No options	threaded connection			
				ISO228		welded connection DIN EN 3239	
				NPT		62 = DN 15	/L = ISO 4200 /M = DIN 11850-2
				23 = 1/2"	53 = 1/2"	63 = DN 20	
				24 = 3/4"	54 = 3/4"	64 = DN 25	
				25 = 1"	55 = 1"	65 = DN 32	
				26 = 1 1/4"	56 = 1 1/4"	66 = DN 40	
				27 = 1 1/2"	57 = 1 1/2"	67 = DN 50	
				28 = 2"	58 = 2"	68 = DN 65	
				29 = 2 1/2"		69 = DN 80	
				30 = 3"			

**Aufbau / Construction :**

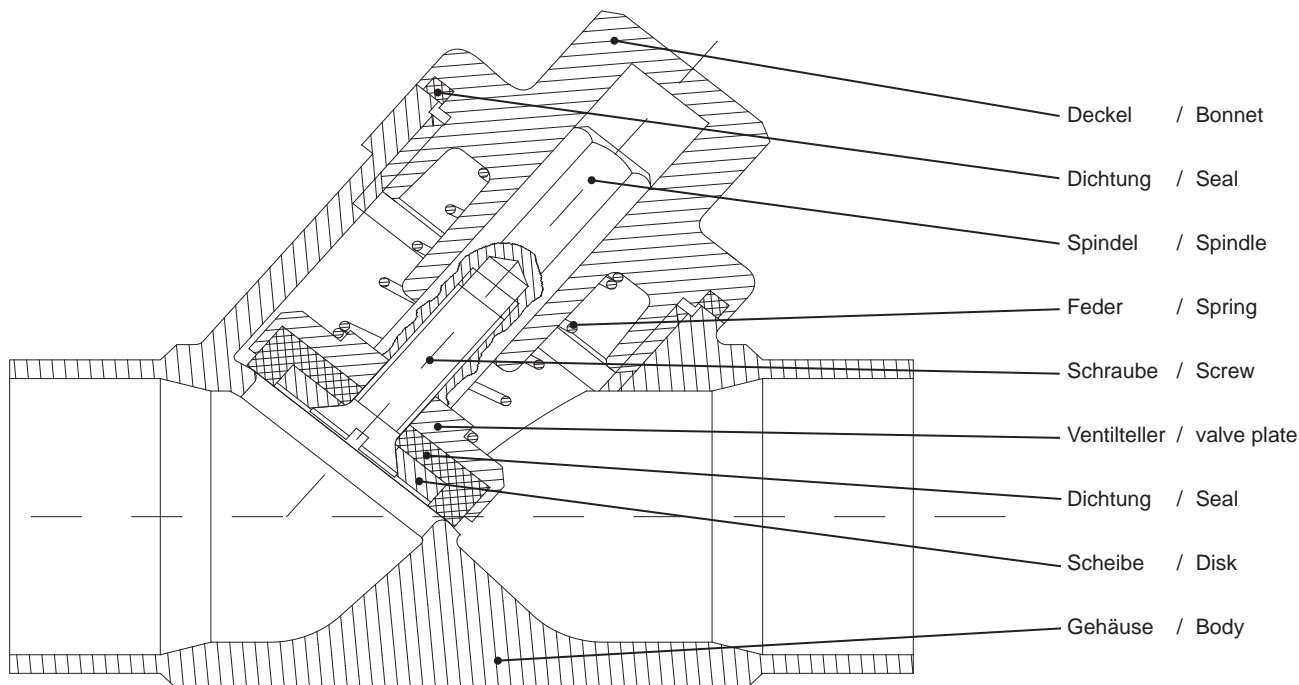

## Abmessungen / dimensions :

"M" Anschweißenden DIN 1185  
"M" Butt weld DIN 11850-2

Anschweißenden DIN 3239  
Butt weld DIN 3239

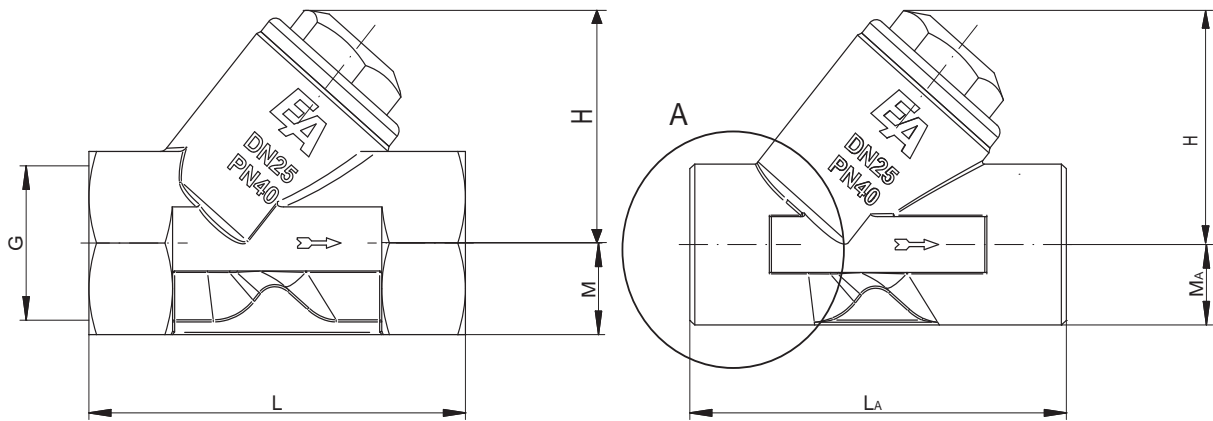

### Detail A

Anschweißenden DIN 3239  
welding end DIN 3239

Anschweißenden ISO 4200  
welding end ISO 4200

Anschweißenden DIN 11850-2 /  
welding end DIN 11850-2

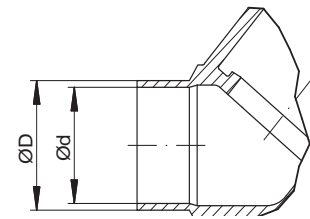
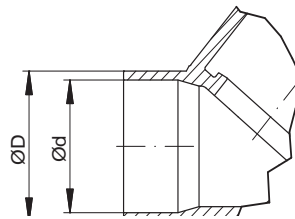
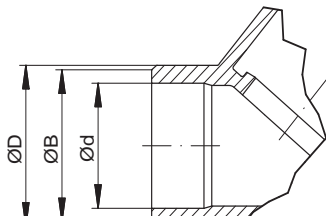

G	DN	L	M	H	kg	Kv- Wert	DIN 3239			L	"L" - ISO 4200		"M" - DIN 11850-2			
							ØB	ØD	Ød		ØD	Ød	ØD	Ød	L	
½	15	65,0	12,5	42,5	0,24	3,8	22	24	17	65,0	21,3	18,1	65,0	19	16	65,0
¾	20	75,0	15,5	49,0	0,40	6,5	28	30	22	75,0	26,9	23,7	75,0	23	20	75,0
1	25	90,0	18,5	57,5	0,65	11,0	34	36	28	90,0	33,7	29,7	90,0	29	26	90,0
1¼	32	110,0	23,0	65,0	1,13	18,5	41	45	35	110,0	42,4	38,4	110,0	35	32	110,0
1½	40	120,0	26,5	74,0	1,52	24,0	49	52	43	120,0	48,3	44,3	120,0	41	38	120,0
2	50	150,0	33,5	85,0	2,61	40,5	61	65	54	150,0	60,3	55,1	150,0	53	50	150,0
2½	65	180,0	42,5	118,0	4,29	-	-	-	-	-	76,1	70,3	205,0	70	66	205,0
3	80	200,0	50,0	128,0	6,05	-	-	-	-	-	88,9	83,1	220,0	85	81	220,0

### Hinweis

Bei den in dieser Dokumentation beschriebenen Produkten, in der von uns gelieferten Form, handelt es sich weder um Maschinen gemäß Artikel 2 Absatz a noch um unvollständige Maschinen gemäß Artikel 2 Absatz g im Sinne der Richtlinie 2006/42/EG über Maschinen.

### Advice

The products described in this documentation in the conditions of our delivery are no machinery according to annex 2 paragraph a respectively no partly completed machinery according to annex 2 paragraph g of the directive 2006/42/EC on machinery.

