

CARBON STEEL GLOBE VALVE WITH BELLOW PN40



Certificate 3.1

Size : DN 15 to DN 200
Ends : Flanges R.F. PN40
Min Temperature : - 20°C
Max Temperature : + 400°C
Max Pressure : 40 Bars
Specifications : Non rising stem
Bolted bonnet and gland pack
Stainless steel bellow

Materials : Carbon steel ASTM A216 WCB

CARBON STEEL GLOBE VALVE WITH BELLOW PN40

SPECIFICATIONS :

- Respect the flow direction indicated by the arrow
- Non rising stem
- Bolted bonnet and gland pack
- Stainless steel bellow
- Pressure equalizing plug in DN200
- Pressed seat in the body
- Anti-turn device to avoid the risk of torsion of bellows
- Flanges R.F. PN40
- RAL 5002 blue painting, 40 μ thickness

USE:

- No corrosive or no toxic fluids, steam, hydrocarbons, thermic fluid
- Min and max Temperature Ts : - 20°C to + 400°C
- Max Pressure Ps : 40 bars (see graph under)
- Δp 20 bars max for DN125, 15 bars max for DN150, 19 bars max for DN200
- Keep greased the stem

FLOW COEFFICIENT Kvs (M3 / h) :

DN	15	20	25	32	40	50	65	80	100	125	150	200
Kvs (m3/h)	3.8	7	10	19	35	43	60	110	146	210	300	670

PRESSURE / TEMPERATURE GRAPH :

Pressure (Bar)

(Bar)

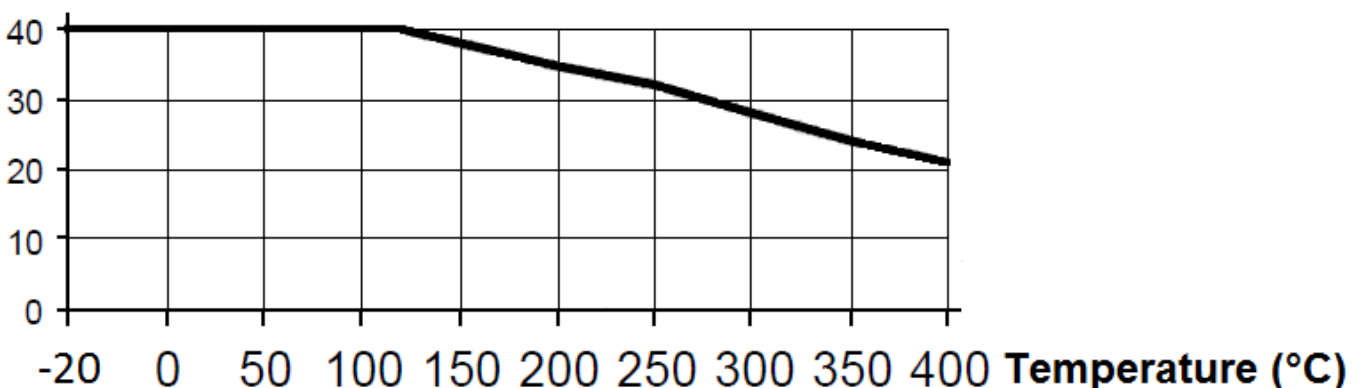

RANGE :

- Carbon steel globe valve with stainless steel bellow flanged R.F. PN40 from DN 15 to DN 200 Ref. 475
- Carbon steel globe valve with stainless steel bellow flanged PN40 type E spigot/ F Recess from DN 15 to DN 150 Ref. 4753

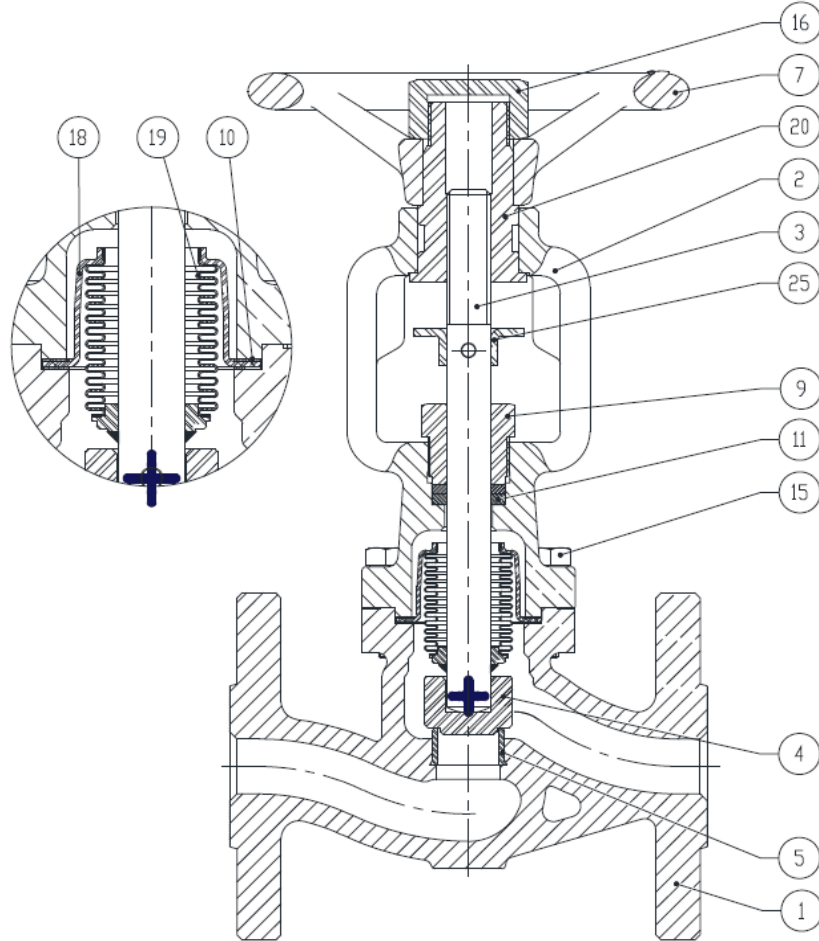
CARBON STEEL GLOBE VALVE WITH BELLOW PN40
MATERIALS DN15-150 :

Item	Designation	Materials
1	Body	ASTM A216 WCB 1.0619
2	Bonnet	
3	Stem	AISI 303 (1.4305)
4	Disc	AISI 420 (1.4021)
5	Seat	X 22 CrNi 17 (1.4059)
7	Handwheel	Ductile iron EN GJS-400
9	Gland	Steel EN 10087
10	Gasket	Graphite
11	Packing	Graphite
15	Screw	Steel C35E
16	Handwheel nut	EN 10087
18	Hood	AISI 303 (1.4305)
19	Bellow	AISI 316 Ti (1.4571)
20	Threaded bushing	Steel EN 10087
25	Anti turn device	Steel EN 10025
	Lubricator	Brass

CARBON STEEL GLOBE VALVE WITH BELLOW PN40

MATERIALS DN200 :

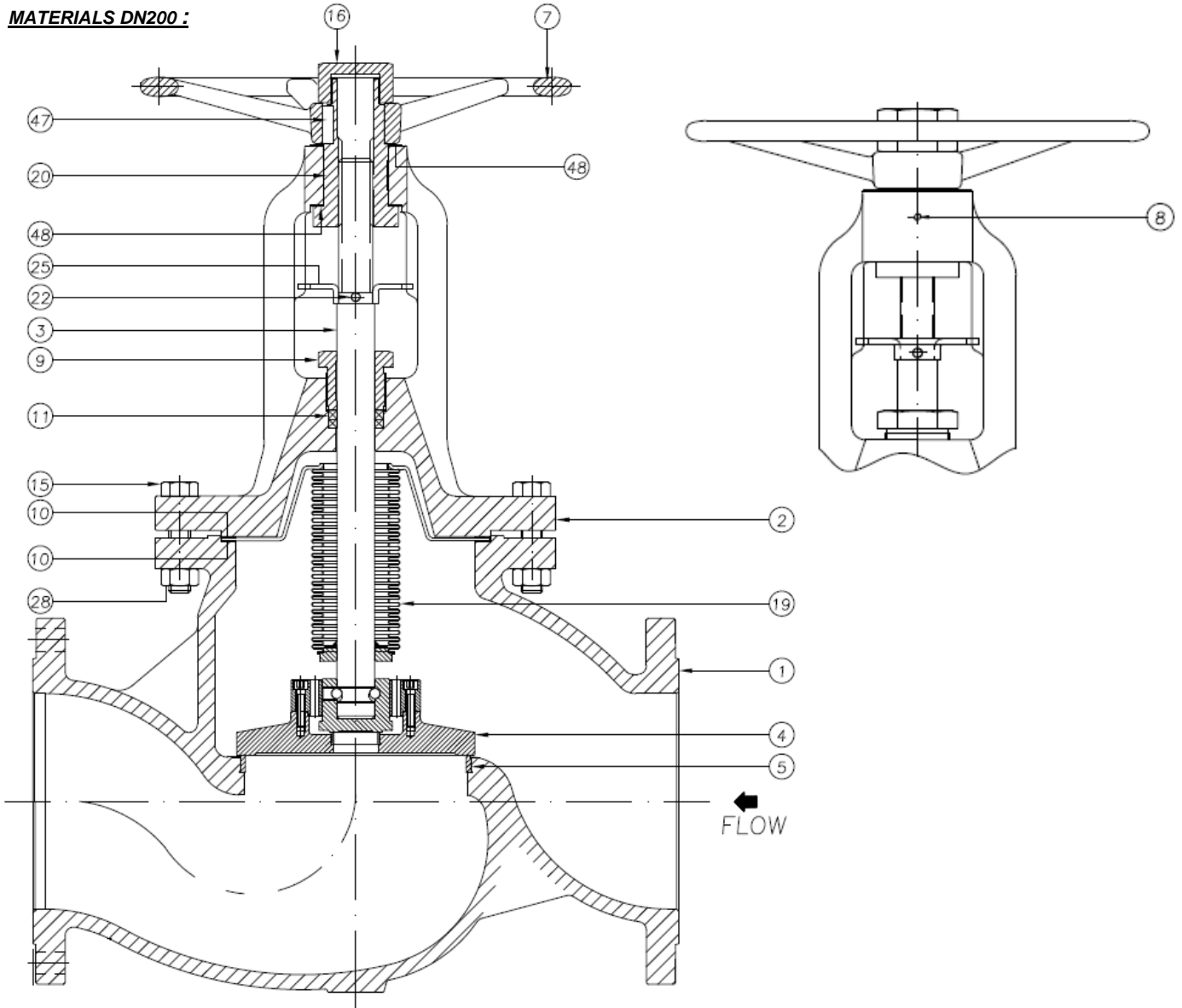

Item	Designation	Materials
1	Body	ASTM A216 WCB 1.0619
2	Bonnet	ASTM A216 WCB 1.0619
3	Stem	AISI 303 (1.4305)
4	Disc	AISI 420 (1.4021)
5	Seat	X 22 CrNi 17 (1.4059)
7	Handwheel	Ductile iron EN GJS-400
8	Grease nipp.	Steel
9	Gland nut	EN 10087
10	Gasket	Graphite

Item	Designation	Materials
11	Packing	Graphite
15	Screw	A193 B7M
16	Handwheel nut	EN 10087
19	Bellow	AISI 316 Ti (1.4571)
20	Threaded bushing	EN 10087
22	Pin	Steel
25	Anti turn device	EN 10025
28	Nut	A194 2HM
47	Key	Steel
48	Washer	Steel

CARBON STEEL GLOBE VALVE WITH BELLOW PN40

DISC OPTIONS :

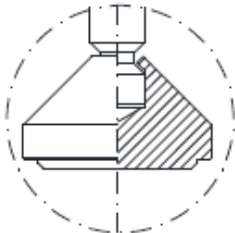
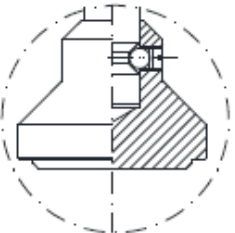
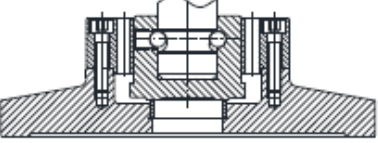
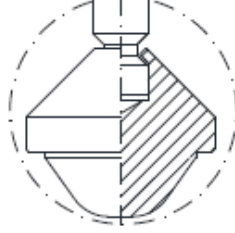
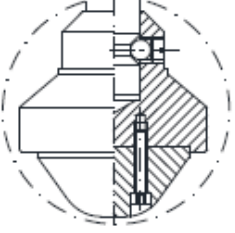
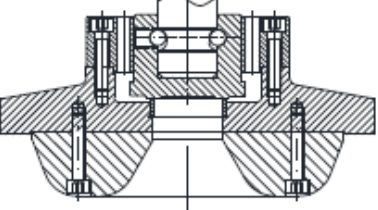
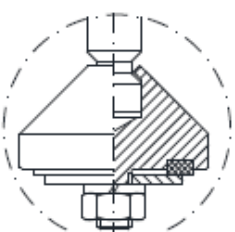
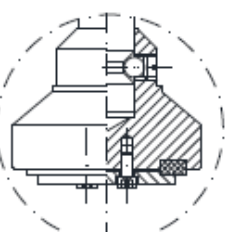
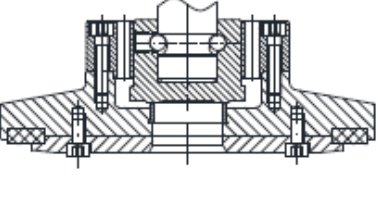
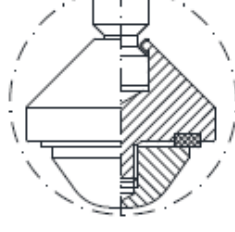
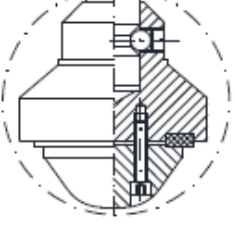
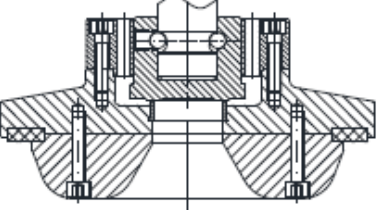
DN 15-65	DN 80-150	DN 200
STANDARD DISC		
		
OPTION A : THROTTLING PLUG*		
		
OPTION B : DISC WITH SOFT SEAT*		
		
OPTION C : THROTTLING PLUG + SOFT SEAT*		
		

* :ON REQUEST

CARBON STEEL GLOBE VALVE WITH BELLOW PN40

SIZE (in mm):

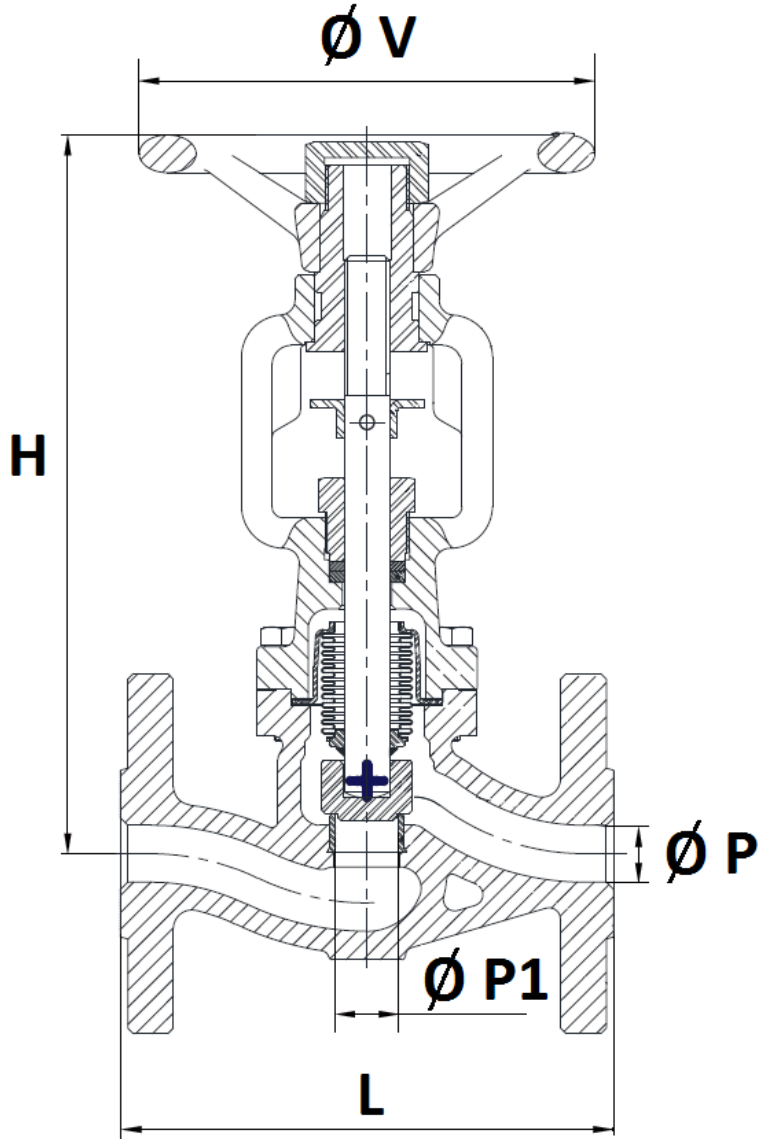

DN	15	20	25	32	40	50	65	80	100	125	150	200
L	130	150	160	180	200	230	290	310	350	400	480	600
Ø P	15	20	25	32	40	50	65	80	100	125	150	200
Ø P1	16.5	20.5	25.2	30	40.8	50.5	66	81	104.5	126	150.5	205
H	190	195	220	219	256	265	328	341	376	488	531	685
Ø V	120	120	140	140	180	180	200	200	250	275	275	400
Weight (Kg)	3.7	4.8	6.8	7.8	13	15.5	23	28	43	68	100	202

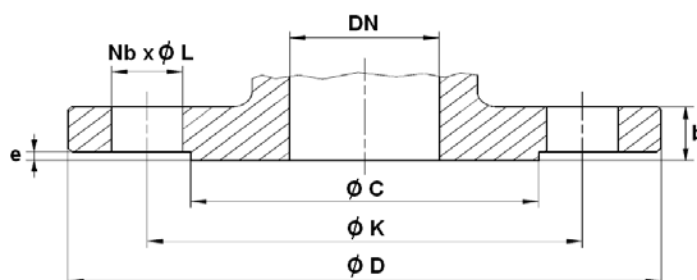
CARBON STEEL GLOBE VALVE WITH BELLOW PN40
FLANGES SIZE (in mm) :

DN	15	20	25	32	40	50	65	80	100	125	150	200
Ø C	45	58	68	78	88	102	122	138	162	188	218	285
Ø D	95	105	115	140	150	165	185	200	235	270	300	375
Ø K	65	75	85	100	110	125	145	160	190	220	250	320
Nb x Ø L	4 x 14	4 x 14	4 x 14	4 x 18	4 x 18	4 x 18	8 x 18	8 x 18	8 x 22	8 x 26	8 x 26	12 x 30
b	16	18	18	18	18	20	22	24	24	26	28	34
e	2	2	2	2	3	3	3	3	3	3	3	3

STANDARDS :

- Fabrication according to ISO 9001 :2015
- DIRECTIVE 2014/68/EU : CE N° 0035
Risk Category III module H
- Certificate 3.1 on request
- Designing according to DIN 3840
- Marking according to EN 19
- Pressure Tests according to EN 12266-1, Rate A
- Length according to EN 558 series 1 (DIN 3202 F1)
- Flanges R.F. according to EN 1092-1 PN40

ADVICE : Our opinion and our advice are not guaranteed and SFERACO shall not be liable for the consequences of damages.
The customer must check the right choice of the products with the real service conditions.

CARBON STEEL GLOBE VALVE WITH BELLOW PN40**INSTALLATION INSTRUCTIONS****GENERAL GUIDELINES :**

- Ensure that the valves to be used are appropriate for the conditions of the installation (type of fluid, pressure and temperature).
- Be sure to have enough valves to be able to isolate the sections of piping as well as the appropriate equipment for maintenance and repair.
- Ensure that the valves to be installed are of correct strength to be able to support the capacity of their usage.
- **Installation of all circuits should ensure that their function can be automatically tested on a regular basis (at least two times a year).**

INSTALLATION INSTRUCTIONS :

- **Before installing the valves, clean and remove any objects from the pipes** (in particular bits of sealing and metal) which could obstruct and block the valves.
- **Ensure that both connecting pipes either side of the valve (upstream and downstream) are aligned (if they're not, the valves may not work correctly).**
- **Make sure that the two sections of the pipe (upstream and downstream) match, the valve unit will not absorb any gaps. Any distortions in the pipes may affect the tightness of the connection, the working of the valve and can even cause a rupture.** To be sure, place the kit in position to ensure the assembling will work.
- **If sections of piping do not have their final support in place, they should be temporarily fixed. This is to avoid unnecessary strain on the valve.**
- Tighten the bolts in cross.
- It's recommended to operate the valve (open and close) 1 to 2 times per year
- Tighten the gland packing at the first start of the installation (with a moderate torque) so that there's no leakage and the handwheel is easy to operate.
- Do not use tools to operate the handwheel
- Respect the flow direction indicated by the arrow