

Butterfly Valve, Metal

Construction

GEMÜ 411, 415 and 428 are centric butterfly valves in the nominal sizes DN 15 – 50. The valve body and disc are made of brass or stainless steel 1.4581. As sealing material are available EPDM, FPM and PSI (silicone-rubber).

GEMÜ 411 has an ergonomically designed corrosion-resistant handwheel with integrated locking device.

GEMÜ 415 has a low-maintenance corrosion-resistant plastic piston actuator. Normally Closed, Normally open and Double Acting control functions are available.

GEMÜ 428 has a low-maintenance electrical actuator with a powerful reversible DC motor. The secondary gear in the motor, consisting of a threaded spindle with swivel lever, provides the rotation through 90°. GEMÜ 428 has an optical position indicator and a manual override.

Features

- Suitable for inert and corrosive* liquid and gaseous media
- Insensitive to viscous media

Advantages

- Various seal materials available to suit the working medium
- Low weight
- Optional accessories (GEMÜ 415)
 - Stroke limiter
 - GEMÜ 1225 electrical position indicator with 2 potential-free adjustable limit switches (additional module, can be retrofitted)
- ATEX version II 2G/2G c IIB TX X, II -/2D c TX X on request

* see information on working medium on page 2



GEMÜ 411



GEMÜ 415



GEMÜ 428

Sectional view valve body

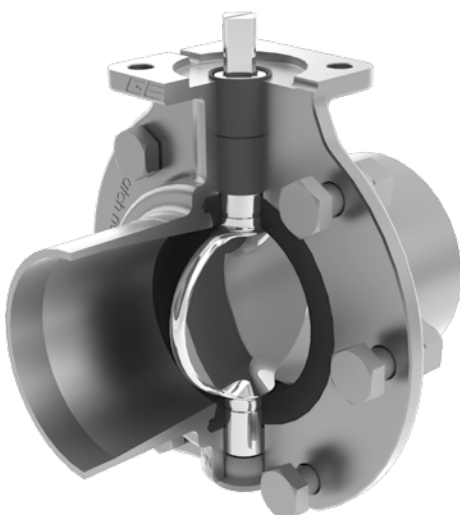

General technical data

Working medium	
Inert, corrosive gaseous and liquid media which have no negative impact on the physical and chemical properties of the body, disc and seal materials	
Max. perm. pressure of working medium	10 bar
Max. perm. temperature of working medium	100 °C

Admissible temperatures	
Ambient temperature	-10...+60 °C
Storage temperature	-20...+60 °C

DN	Kv value [m ³ /h]		Weight [g]					
	Brass (Code 12)	1.4581 (Code 38)	GEMÜ 411		GEMÜ 415		GEMÜ 428	
	Brass (Code 12)	1.4581 (Code 38)	Brass (Code 12)	1.4581 (Code 38)	Brass (Code 12)	1.4581 (Code 38)	Brass (Code 12)	1.4581 (Code 38)
15	7	7*	800	700	1000	900	1700	1600
20	12	15*	850	700	1050	900	1750	1600
25	17	20*	900	700	1100	900	1800	1600
32	40	55*	1050	800	1550	1300	2050	1800
40	60	90*	1600	1200	2600	2200	2600	2200
50	100	140*	2200	1600	3200	2600	3500	2900

*Connection ISO.

Order data GEMÜ 411, 415

Body configuration	Code
2/2 way	D

Connections	Code
Butt weld spigots (only valve body material code 38)	
Spigots DIN	0
Spigots DIN 11850, series 1	16
Spigots DIN 11850, series 2	17
Spigots DIN 11850, series 3	18
Spigots SMS 3008	37
Spigots ASME BPE	59
Spigots EN ISO 1127	60
Threaded connections (only valve body material code 12)	
Threaded sockets DIN ISO 228	1

Valve body material	Code
CW617N (Brass), (disc CW617N) only available with threaded socket design	12
1.4581, St. steel investment casting only available with butt weld spigot design	38

Seal material	Code
FPM	4
PSI, Silicone rubber	9
EPDM	14

Control function	Code
Manually operated (GEMÜ 411)	0
Normally closed (NC) (GEMÜ 415)	1
Normally open (NO) (GEMÜ 415) (by rotating the actuator 90° during assembly)	2
Double acting (DA) (GEMÜ 415)	3

Actuator size	Code
Actuator ø 50 mm	0
Actuator ø 70 mm	1

Order example	415	25	D	7	1	12	3	0
Type	415							
Nominal size		25						
Body configuration (Code)			D					
Connection (Code)				7				
Valve body material (Code)					1			
Seal material (Code)						12		
Control function (Code)							3	
Actuator size (Code)								0

Technical data GEMÜ 415

Control pressure [bar]				
DN	Control function 1		Control function 3	
	Actuator		Actuator	
	0	1	0	1
15	5.5 - 6.0	-	3.0 - 6.0	-
20	5.5 - 6.0	-	3.0 - 6.0	-
25	5.5 - 6.0	-	3.0 - 6.0	-
32	-	5.5 - 6.0	-	2.0 - 6.0
40	-	5.5 - 6.0	-	2.0 - 6.0
50	-	5.5 - 6.0	-	2.0 - 6.0

All pressures are given as gauge pressures.

Control medium

Inert gases	
Max. control pressure	6 bar
Max. perm. temperature of control medium	60 °C
Filling volume actuator 0	0.05 dm ³
Filling volume actuator 1	0.20 dm ³
Other control media upon request	

Technical data GEMÜ 428

Protection class to EN 60529

IP 65

Permissible temperatures

Ambient temperature	-10 to +60 °C
Storage temperature	-20 to +60 °C

Weight

Supply voltage 12 V / 24 V	1.0 kg
Supply voltage 100-250 V	1.2 kg

Mounting position

Optional

Manual override

with Allen key SW3

Actuator material

Housing cover	PPE + 30 % glass fibre reinforced
Housing base	PP + 30 % glass fibre reinforced
Optical position indicator	PP-R natural

Travel

Nominal travel	90°
Max. travel	93°
Setting range limit switch Min.	-2 to 12°
Setting range limit switch Max.	76 to 91°

Torque

Actuator version 1006, 2006	6 Nm
Actuator version 1015, 2015	15 Nm

Operating times

Actuator version 1006, 2006	approx. 4 sec
Actuator version 1015, 2015	approx. 11 sec

Correlation Actuator version / Connection size

Actuator version	Connection size (code)			
	G05	F03	F04	F05
1006	S08	S09	S09	S09/S11
1015	S08	S09	S09	S09/S11
2006	S08	S09	S09	S09/S11
2015	S08	S09	S09	S09/S11

Wrench size S08, S09, S11, S14 - (double square drive)

Technical data GEMÜ 428

Power supply

Rated voltage	12 V / 24 V AC or DC 100 - 250 V AC
Rated frequency (at AC rated voltage)	50/60 Hz
Voltage tolerance	± 10 %

Output signals (option)

Potential-free limit switches	Change-over contact 250 V AC/6A
-------------------------------	------------------------------------

Power and current consumption

Actuator version Code	12 V DC	24 V DC	12 V AC	24 V AC	100-250 V AC
	Code B1	Code C1	Code B4	Code C4	Code O4
Power consumption [W]					
1006	30	30	30	60	-
1015	30	30	-	-	-
2006	-	-	-	-	60
2015	-	-	30	30	50
Current consumption - Rated current [A]					
1006	2.2	1.2	2	1.5	-
1015	2.2	1.2	-	-	-
2006	-	-	-	-	0.25
2015	-	-	2	1.2	0.20
Current consumption - max. current at start up [A]					
1006	6.3	4.0	2.4	1.8	-
1015	9.2	3.8	-	-	-
2006	-	-	-	-	0.3
2015	-	-	2.3	1.8	0.4

Duty cycle

Supply voltage 12 V / 24 V	Continuous duty
Supply voltage 100 - 250 V	40 % duty

Electrical protection

Supply voltage 12 V / 24 V	Motor protective system by customer
Supply voltage 100 - 250 V	Integrated stall and overload protection plus excess current release T 1A 5x20 mm

Electrical connection

Supply voltage 12 V / 24 V	
Connection	Cable gland PG 13.5
Cable diameter	7.5 ... 12.5 mm
Max. cross section of wire	1.5 mm ²
Recommended connection cable	5x1 mm ²
Supply voltage 100 - 250 V	
Connection	Hirschmann plug Type N6RFFS11 (PG 11)
Cable diameter	7 ... 9 mm
Max. cross section of wire	1.5 mm ²
Recommended connection cable	1 connector. (Standard): 7x1 mm ²

Protection class to DIN EN 61140

I

Recommended motor protection

Voltage	Motor protection switch Type	Set current
12 V DC	Siemens 3RV 1011-1CA10	2.20 A
12 V AC	Siemens 3RV 1011-1CA10	2.00 A
24 V DC	Siemens 3RV 1011-1BA10	1.70 A
24 V AC	Siemens 3RV 1011-1BA10	1.60 A
120 V AC	Siemens 3RV 1011-OGA10	0.60 A
230 V AC	Siemens 3RV 1011-OGA10	0.45 A

Order data

Body configuration	Code
2/2 way	D

Connections	Code
Butt weld spigots (only valve body material code 38)	
Spigots DIN	0
Spigots DIN 11850, series 1	16
Spigots DIN 11850, series 2	17
Spigots DIN 11850, series 3	18
Spigots SMS 3008	37
Spigots ASME BPE	59
Spigots EN ISO 1127	60
Threaded connections (only valve body material code 12)	
Threaded sockets DIN ISO 228	1

Valve body material	Code
CW617N (Brass), (disc CW617N) only available with threaded socket design	12
1.4581, St. steel investment casting only available with butt weld spigot design	38

Seal material	Code
FPM	4
PSI, Silicone rubber	9
EPDM	14

Voltage/frequency	Code
12 V DC	B1
12 V AC 50/60 Hz	B4
24 V DC	C1
24 V AC 50/60 Hz	C4
100-250 V AC 50/60 Hz	O4

Functional module	Code
OPEN/CLOSED control standard	A0
OPEN/CLOSED control with 2 additional potential-free limit switches	AE

Actuator version	Code
6 Nm (supply voltage B1,C1,B4,C4)	1006
6 Nm (supply voltage O4)	2006
15 Nm (supply voltage B1,C1)	1015
15 Nm (supply voltage B4,C4,O4)	2015

Special version	K-No.
Parallel operation*	6410
Connection with 1 Hirschmann socket DIN 43651 Type N6RFFS11 Cable diameter 7...9 mm; wire cross section up to 1.5 mm ² ; PG11)*	6598
Connection with 2 Harting plugs HAN 7D (only functional code AE)	6722
* not possible for supply voltage code O4	

Order example	428	25	D	1	12	14	C1	A0	1006	-
Type	428									
Nominal size		25								
Body configuration (code)			D							
Connection (code)				1						
Valve body material (code)					12					
Seal material (code)						14				
Supply voltages/frequency (code)							C1			
Functional module (code)								A0		
Actuator version (code)									1006	
Special design (K-No.)										-

Body dimensions [mm]

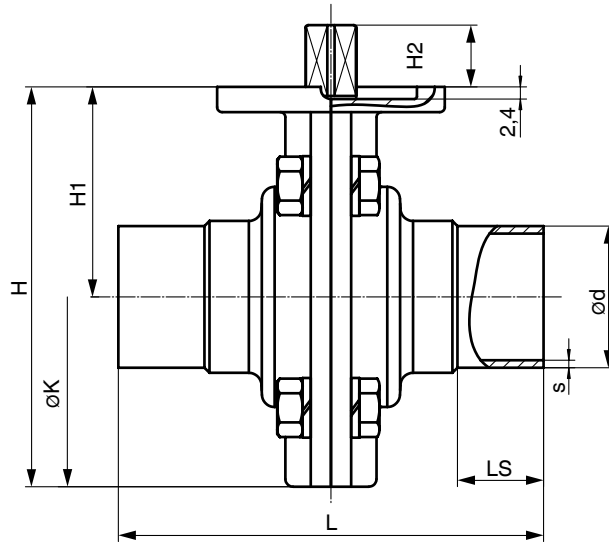

Butt weld spigots

DN	NPS	L	H	H1	H2	øK	LS	DIN series 0; Code 0		DIN 11850 series 1; Code 16		DIN 11850 series 2; Code 17		DIN 11850 series 3; Code 18		SMS 3008 Code 37		EN ISO 1127 Code 60		ASME BPE Code 59	
								ød	s	ød	s	ød	s	ød	s	ød	s	ød	s	ød	s
15	1/2"	80	79	41.5	13	75	20	18	1.5	18	1	19	1.5	20	2	-	-	21.3	1.6	12.70	1.65
20	3/4"	84	79	41.5	13	75	22	22	1.5	22	1	23	1.5	24	2	-	-	26.9	1.6	19.05	1.65
25	1"	84	79	41.5	13	75	22	28	1.5	28	1	29	1.5	30	2	25.0	1.2	33.7	2.0	25.40	1.65
32	1 1/4"	88	91	48.0	13	85	25	34	1.5	34	1	35	1.5	36	2	33.7	1.2	42.4	2.0	-	-
40	1 1/2"	96	108	56.0	13	103	25	40	1.5	40	1	41	1.5	42	2	38.0	1.2	48.3	2.0	38.10	1.65
50	2	110	123	65.0	13	116	30	52	1.5	52	1	53	1.5	54	2	51.0	1.2	60.3	2.0	50.80	1.65

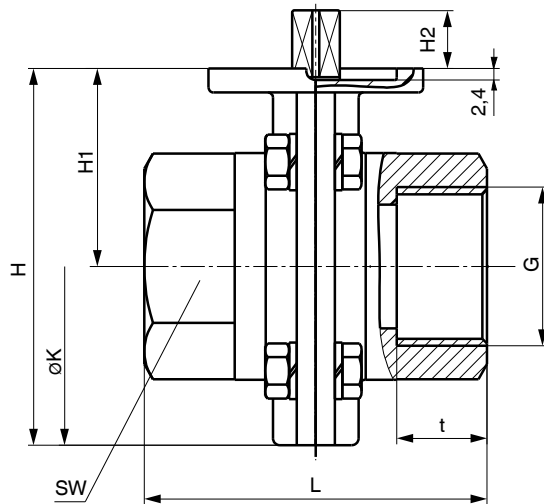

Threaded socket DIN ISO 228

DN	G	H	H1	H2	t	L	øK	SW	Number of wrench surfaces
15	1/2	79	41.5	13	15.0	72	75	27	6
20	3/4	79	41.5	13	16.0	72	75	32	6
25	1	79	41.5	13	19.0	72	75	41	6
32	1 1/4	91	48.0	13	21.4	72	85	50	8
40	1 1/2	108	56.0	13	21.4	83	103	55	8
50	2	123	65.0	13	25.7	88	116	70	8

Actuator dimensiones GEMÜ 411 [mm]

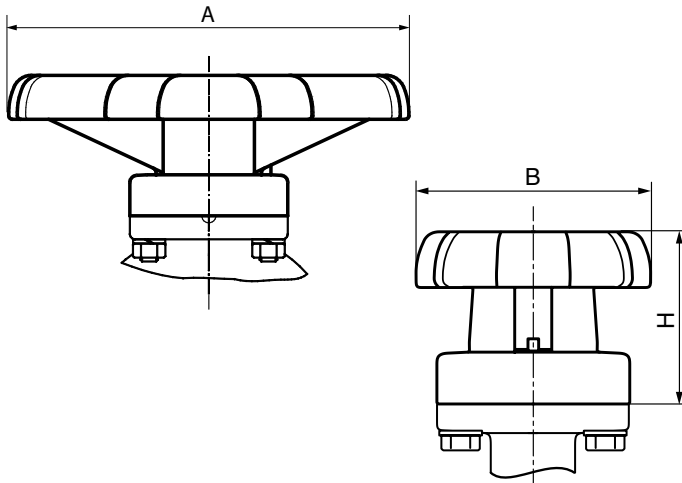

DN	A	B	H
15 - 25	118	55	42
32 - 50	160	71	63

Actuator dimensiones GEMÜ 415 [mm]

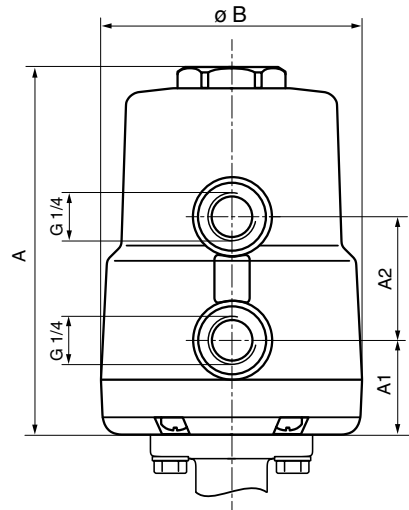

Actuator size	DN	ø B	A	A1	A2
Actuator 0	15 - 25	72	112	37	34
Actuator 1	32 - 50	97	177	41	65

Actuator dimensiones GEMÜ 428 [mm]

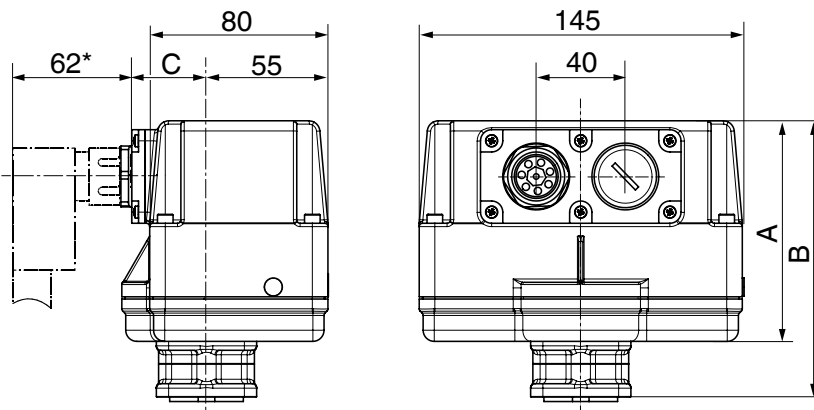

* Standard with supply voltage reference number O4*

Overall height	Voltages	A	B	C
1	12 V, 24 V	69	94	49
2	100 V - 250 V	99	124	53

Actuator mounting dimensions [mm]

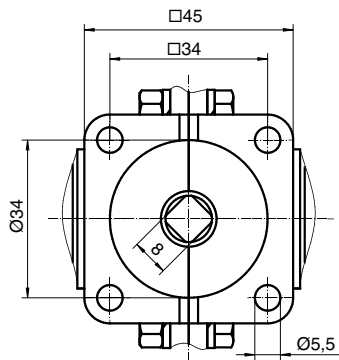

Valve connection dimensions [mm]

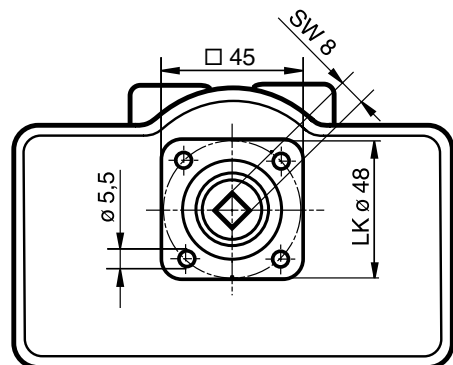

Valve body mounting dimensions [mm]

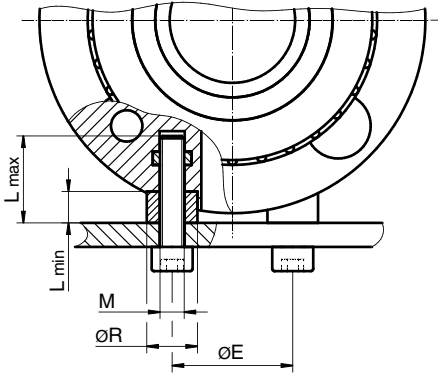

DN	M	E	ØR	L _{max}	L _{min}
15	M 5	25	10	18	7
20	M 5	25	10	18	7
25	M 5	25	10	18	7
32	M 6	65	33	33	22
40	M 6	80	41	41	30
50	M 6	80	41	41	30

Electrical connections [mm]

OPEN / CLOSE version - 12 / 24 V DC (Code A0)

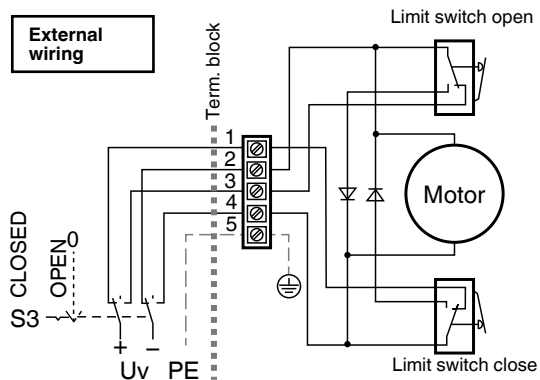
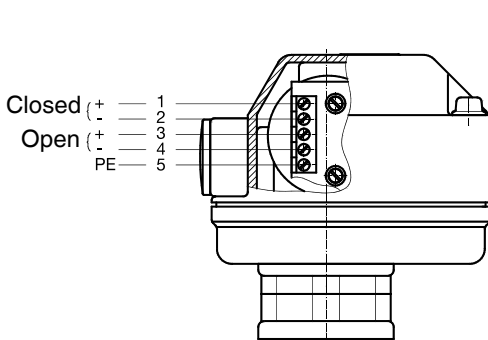

Terminals must not be bridged!

If parallel connection of several actuators is required, the variant with K-No. 6410 must be used.

OPEN / CLOSE control - 12 / 24 V AC (Code A0)

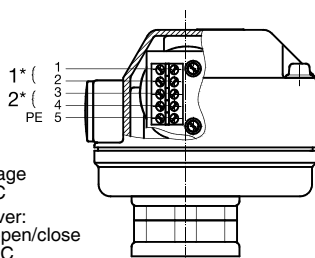

1*) Motor voltage

12/24 V AC

2*) Change-over:

Direction open/close

12V/24V AC

Ad 2*) Change-over voltage: On = direction of travel „Open“
Off = direction of travel „Closed“

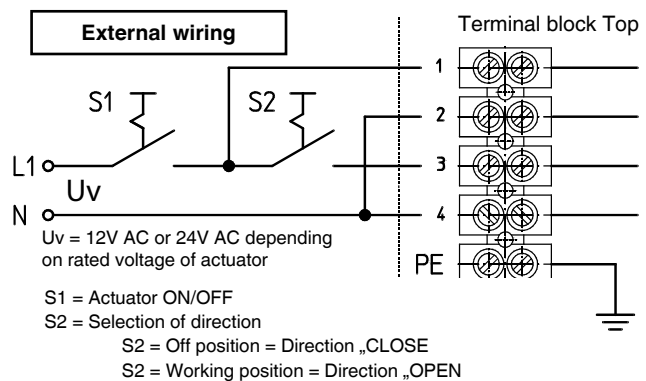

2 potential-free limit switches - 12 / 24 V DC (Code AE)

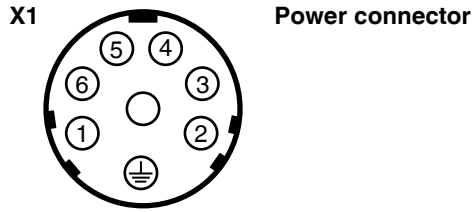

Pin	Signal name
1	L+, Direction of travel OPEN
2	L-, Direction of travel OPEN
3	L+, Direction of travel CLOSE
4	L-, Direction of travel CLOSE
5	n.c.
6	n.c.
⊕	PE, Protective earth conductor

Terminals must not be bridged!

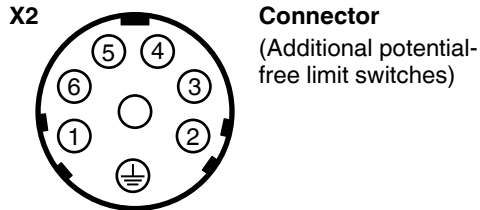

Pin	Signal name
1	S 1:1, Change-over contact limit switch CLOSE
2	S 1:4, Make-contact limit switch CLOSE
3	S 1:2, Break-contact limit switch CLOSE
4	S 2:2, Break-contact limit switch OPEN
5	S 2:4, Make-contact limit switch OPEN
6	S 2:1, Change-over contact limit switch OPEN
⊕	PE, Protective earth conductor

X1, X2 = Connector Type Hirschmann N6RAM2931592-001

2 potential-free limit switches - 12 / 24 V AC (Code AE)

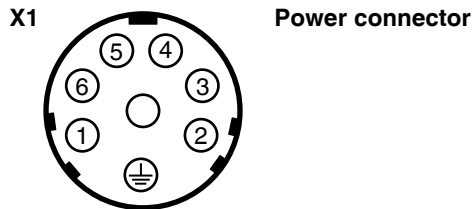

Pin	Signalname
1	L1 / L+, Supply voltage
2	N1 / L-, Supply voltage
3	L1 / L+, Direction of travel OPEN
4	N / L-, Direction of travel OPEN
5	n.c.
6	n.c.
⊕	PE, Protective earth conductor

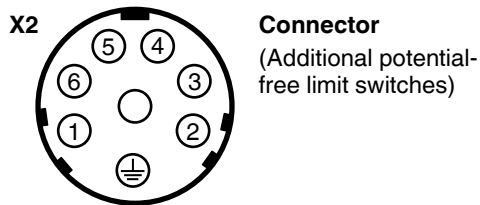

Pin	Signal name
1	S 1:1, Change-over contact limit switch CLOSE
2	S 1:4, Make-contact limit switch CLOSE
3	S 1:2, Break-contact limit switch CLOSE
4	S 2:2, Break-contact limit switch OPEN
5	S 2:4, Make-contact limit switch OPEN
6	S 2:1, Change-over contact limit switch OPEN
⊕	PE, Protective earth conductor

Without signal „direction of travel OPEN“ the actuator closes.
X1, X2 = Connector Type Hirschmann N6RAM2931592-001

OPEN / CLOSE control - 100-250 V AC (Code A0)

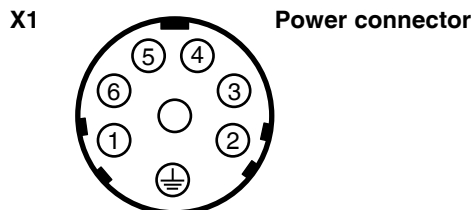

Pin	Signal name
1	L1 / L+, Supply voltage
2	N1 / L-, Supply voltage
3	L1 / L+, Direction of travel CLOSE
4	N / L-, Direction of travel CLOSE
5	L1 / L+, Direction of travel OPEN
6	N / L-, Direction of travel OPEN
⊕	PE, Protective earth conductor

N/L signals in the unit are separated.
Potential assignment by customer.

2 potential-free limit switches - 100-250 V AC (Code AE)

X1

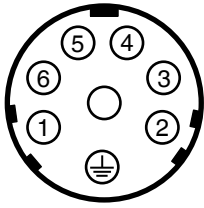

Power connector

Pin	Signal name
1	L1 / L+, Supply voltage
2	N1 / L-, Supply voltage
3	L1 / L+, Direction of travel CLOSE
4	N / L-, Direction of travel CLOSE
5	L1 / L+, Direction of travel OPEN
6	N / L-, Direction of travel OPEN
⊕	PE, Protective earth conductor

N/L signals in the unit are separated.
Potential assignment by customer.

X2

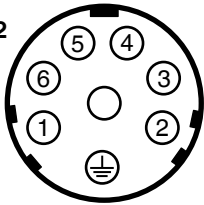

Connector
(Additional potential-free limit switches)

Pin	Signal name
1	S 1:1, Change-over contact limit switch CLOSE
2	S 1:4, Make-contact limit switch CLOSE
3	S 1:2, Break-contact limit switch CLOSE
4	S 2:2, Break-contact limit switch OPEN
5	S 2:4, Make-contact limit switch OPEN
6	S 2:1, Change-over contact limit switch OPEN
⊕	PE, Protective earth conductor

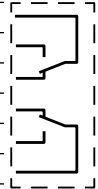

X1, X2 = Connector type Hirschmann N6RAM2931592-001

All rights including copyright and industrial property rights are expressly reserved.

Should there be any doubts or misunderstandings, the German version of this data sheet is the authoritative document!

Subject to alteration · 02/2016 · 88369566

Overview of valve bodies for GEMÜ 411

DN	Brass (Code 12)	1.4581, Investment casting (Code 38)						
	Threaded socket Code 1	Butt weld spigots						
		DIN series 0; Code 0	DIN 11850 series 1; Code 16	DIN 11850 series 2; Code 17	DIN 11850 series 3; Code 18	SMS 3008 Code 37	EN ISO 1127 Code 60	ASME BPE Code 59
15	X	X	X	X	X	-	X	X
20	X	X	X	X	X	-	X	X
25	X	X	X	X	X	X	X	X
32	X	X	X	X	X	X	X	-
40	X	X	X	X	X	X	X	X
50	X	X	X	X	X	X	X	X

For plastic butterfly valves up to DN 250 mm and metal butterfly valves up to DN 1200 mm as well as accessories please refer to separate data sheets.
Contact GEMÜ.

GEMÜ® VALVES, MEASUREMENT
AND CONTROL SYSTEMS

