

Check Valve, Metal

Construction

The GEMÜ 560 check valve comprises an angle seat valve body in investment cast stainless steel and a PTFE or PFA seat for tight shut off. The valve is available with various connection types.

Features

- Suitable for inert and corrosive* and liquid media

Advantages

- Good flow capability due to angle seat design
- Different connection codes for worldwide use

*see information on working medium on page 2



Sectional drawing

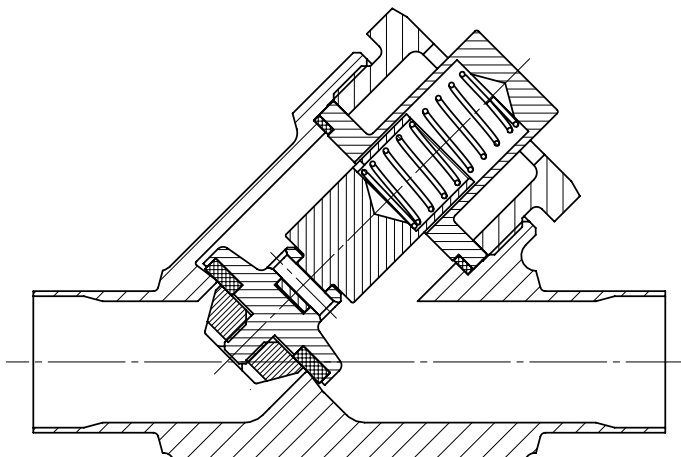

Technical data

Working medium

Corrosive, inert and liquid media which have no negative impact on the physical and chemical properties of the body and seal material.

Media temperature

Seat seal PTFE code 5 -10 °C to 180 °C

Seat seal PFA code 30 -10 °C to 160 °C

Other versions for lower/higher temperatures and higher viscosities on request.

Operating pressure

DN 6 - 15 Operator size 0 25 bar

DN 8 - 40 Operator size 1 25 bar

DN 50 Operator size 1 20 bar

Ambient conditions

Max. ambient temperature 60 °C

Maximum permissible seat leakage rate

Seat seal	Standard	Test procedure	Leakage rate	Test medium
PTFE, PFA	DIN EN 12266-1	P12	A	air

Nominal size	Opening pressure	Weight
DN	[bar]	[kg]
6 - 15 (Operator size 0)	approx. 0.2	0.21
8 - 15 (Operator size 1)		0.48
20 (Operator size 1)		0.70
25 (Operator size 1)		0.78
32 (Operator size 1)		1.53
40 (Operator size 1)		1.74
50 (Operator size 1)		2.70

All pressures are gauge pressures.

Pressure / temperature correlation for angle seat globe valve bodies

Connection code	Material code	Max. allowable operating pressures in bar at temperature °C*					
		RT	100	150	200	250	300
1, 17, 60, 63	37	25.0	23.8	21.4	18.9	17.5	16.1
0, 16, 17, 18, 37, 59, 60, 65	34	25.0	24.5	22.4	20.3	18.2	16.1
0, 16, 17, 18, 59, 60	40	25.0	20.6	18.7	17.1	15.8	14.8
17, 59, 60	C2	25.0	21.2	19.3	17.9	16.8	15.9

* The valves can be used down to -10°C

RT = Room temperature

All pressures are gauge pressures.

Order data

Body configuration	Code
2/2-way body	D

Connection	Code
Butt weld spigots	
Spigots DIN	0
Spigots EN 10357 series B	16
Spigots EN 10357 series A (formerly DIN 11850 series 2) / DIN 11866 series A	17
Spigots DIN 11850 series 3	18
Spigots SMS 3008	37
Spigots ASME BPE	59
Spigots ISO 1127 / EN 10357 series C / DIN 11866 series B	60
Spigots ANSI/ASME B36.19M Schedule 10s	63
Spigots ANSI/ASME B36.19M Schedule 40s	65
Threaded connections	
Threaded sockets DIN ISO 228	1

Valve body material	Code
1.4435 (ASTM A 351 CF3M \cong 316L), Investment cast.	34
1.4408, Investment casting	37
1.4435 (316 L), Forged body	40
1.4435, Investment casting	C2*
Material equivalency 316 L	
* A surface finish from the order code table "K number" must be specified for valve body material C2.	

Seat seal	Code
PTFE	5
PFA (only Actuator size 0)	30

Operator size	Code
Operator (DN 6 - 15 Seat seal PFA)	0
Operator (DN 8 - 50 Seat seal PTFE)	1

Special versions	Code
Surface finish for valve body material C2	
Ra \leq 0.6 μm (25 μinch) for process contact surfaces, in accordance with ASME BPE SF2 + SF3, mechanically polished internal	1903
Ra \leq 0.8 μm (30 μinch) for process contact surfaces, in accordance with DIN 11866 H3, mechanically polished internal	1904
Ra \leq 0.4 μm (15 μinch) for process contact surfaces, in accordance with DIN 11866 H4, ASME BPE SF1, mechanically polished internal	1909

Order example	560	25	D	60	34	5	1
Type	560						
Nominal size		25					
Body configuration (code)			D				
Connection (code)				60			
Valve body material (code)					34		
Seat seal (code)						5	
Operator size (code)							1
K-Number (code)							

Dimensions [mm]

Butt weld spigots, connection code 0, 16, 17, 18, 37, 60 Valve body material: 1.4435 (Code 34), 1.4408 (code 37)

					Connection code											
Material code 34		Material code 37			0		16		17		18		37		60	
DN	L	LB	L	LB	$\varnothing d$	s	$\varnothing d$	s	$\varnothing d$	s	$\varnothing d$	s	$\varnothing d$	s	$\varnothing d$	s
10	105	35.5	-	-	-	-	12	1.0	13	1.5	14	2.0	-	-	17.2	1.6
15	105	35.5	100	33	18	1.5	18	1.0	19	1.5	20	2.0	-	-	21.3	1.6
20	120	39.0	108	33	22	1.5	22	1.0	23	1.5	24	2.0	-	-	26.9	1.6
25	125	38.5	112	32	28	1.5	28	1.0	29	1.5	30	2.0	25.0	1.2	33.7	2.0
32	155	48.0	137	39	-	-	34	1.0	35	1.5	36	2.0	-	-	42.4	2.0
40	160	47.0	146	40	40	1.5	40	1.0	41	1.5	42	2.0	38.0	1.2	48.3	2.0
50	180	48.0	160	38	52	1.5	52	1.0	53	1.5	54	2.0	51.0	1.2	60.3	2.0

For materials see overview on last page

Butt weld spigots, connection code 59, 63, 65 Valve body material: 1.4435 (Code 34), 1.4408 (code 37)

					Connection code					
Material code 34		Material code 37			59		63		65	
DN	L	LB	L	LB	$\varnothing d$	s	$\varnothing d$	s	$\varnothing d$	s
10	105	35.5	-	-	-	-	-	-	-	-
15	105	35.5	100	33	12.70	1.65	21.3	2.11	21.3	2.77
20	120	39.0	108	33	19.05	1.65	26.7	2.11	26.7	2.87
25	125	38.5	112	32	25.40	1.65	33.4	2.75	33.4	3.88
32	155	48.0	137	39	-	-	-	-	42.4	3.56
40	160	47.0	146	40	38.10	1.65	48.3	2.77	48.3	3.68
50	180	48.0	160	38	50.80	1.65	60.3	2.77	60.3	3.91

For materials see overview on last page

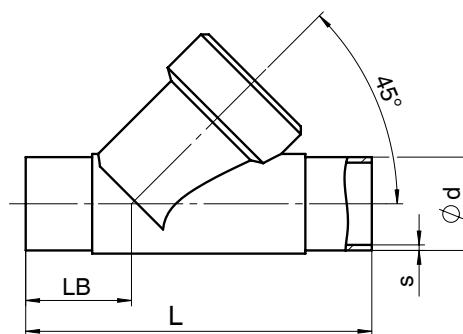

Dimensions [mm]

Butt weld spigots, connection code 0, 16, 17, 59, 60 Valve body material: Schmiedekörper (code 40)

			Connection code											
			0		16		17		18		59		60	
DN	L	LB	ø d	s	ø d	s	ø d	s	ø d	s	ø d	s	ø d	s
6*	80	26.5	8	1.0	-	-	-	-	-	-	-	-	-	-
8*	80	26.5	10	1.0	-	-	-	-	-	-	-	-	13.5	1.6
10*	80	26.5	-	-	12	1.0	13	1.5	14	2.0	9.53	0.89	.	.
15*	80	26.5	-	-	-	-	-	-	-	-	12.70	1.65	.	.

* only with operator size 0

Butt weld spigots, connection code 17, 59, 60 Valve body material: 1.4435 (code C2)

			Connection code					
			17		60		59	
DN	L	LB	ø d	s	ø d	s	ø d	s
8	105	35.5	-	-	13.5	1.6	-	-
10	105	35.5	13	1.5	17.2	1.6	-	-
15	105	35.5	19	1.5	21.3	1.6	12.70	1.65
20	120	39.0	23	1.5	26.9	1.6	19.05	1.65
25	125	39.5	29	1.5	33.7	2.0	25.40	1.65
32	155	48.0	35	1.5	42.4	2.0	-	-
40	160	47.0	41	1.5	48.3	2.0	38.10	1.65
50	180	48.0	53	1.5	60.3	2.0	50.80	1.65

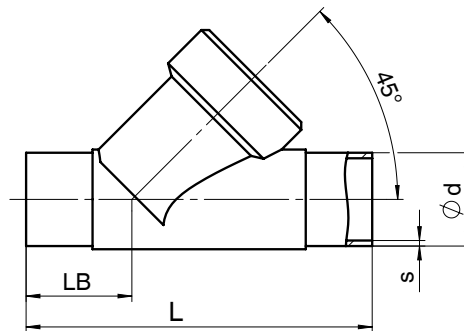

Dimensions [mm]

Threaded sockets DIN, connection code 1 Valve body material: 1.4408 (code 37)

DN	L	LB	R	t	SW2	
15	65	16.5	G 1/2	15.0	27	6-kt
20	75	17.5	G 3/4	16.3	32	6-kt
25	90	24.0	G 1	19.1	41	6-kt
32	110	33.0	G 1 1/4	21.4	50	8-kt
40	120	30.0	G 1 1/2	21.4	55	8-kt
50	150	40.0	G 2	25.7	70	8-kt

* only with bonnet size 0

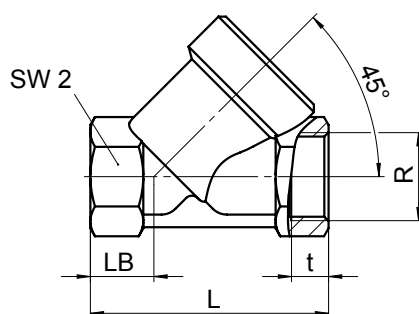

Overview of metal bodies for GEMÜ 560

Connection code	Spigots																			Threaded connections		
	0		16		17				18		37		59				60				63	65
Material code	34	40	34	40	34	37	40	C2	34	40	34	34	40	C2	34	37	40	C2	37	34	37	
DN 6		X*																		-	-	-
DN 8	-	X*	-	-	-	-	-	-	-	-	-	-	-	-	-	-	X*	X	-	-	-	-
DN 10	-	-	X	X*	X	-	X*	X	X	X*	-	-	X*	-	X	-	-	X	-	-	-	-
DN 15	X	-	X	-	X	X	-	X	X	-	-	X	X*	X	X	X	-	X	X	X	X	X
DN 20	X	-	X	-	X	X	-	X	X	-	-	X	-	X	X	X	-	X	X	X	X	X
DN 25	X	-	X	-	X	X	-	X	X	-	X	X	-	X	X	X	-	X	X	X	X	X
DN 32	-	-	X	-	X	X	-	X	X	-	-	-	-	-	X	X	-	X	-	X	X	X
DN 40	X	-	X	-	X	X	-	X	X	-	X	X	-	X	X	X	-	X	X	X	X	X
DN 50	X	-	X	-	X	X	-	X	X	-	X	X	-	X	X	X	-	X	X	X	X	X

* only with actuator size 0

For further check valves, accessories and other products, please see our Product Range catalogue and Price List.
Contact GEMÜ.

GEMÜ® VALVES, MEASUREMENT
AND CONTROL SYSTEMS

