

Diaphragm Valve, Metal

Construction

The GEMÜ 695 pneumatically operated 2/2-way diaphragm valve has a low maintenance membrane actuator which can be controlled by inert gaseous media. Normally Closed, Normally Open and Double Acting control functions are available.

Features

- Suitable for inert and corrosive* liquid and gaseous media
- Insensitive to particulate media
- Valve body and diaphragm available in various materials and designs
- Surface finishes down to 0.25 µm, electropolished
- Versions according to ATEX on request
- Optical position indicator is standard for control function 1

Advantages

- Optional flow direction
- Installation for an optimized draining is possible
- Weight-saving design
- Optional accessories:
 - Stroke limiter
 - Optical position indicator control function 2 + 3
 - Manual override (GEMÜ 1002, GEMÜ 1004)
 - Pilot valve with manual override (GEMÜ 0322 - 0326)
 - Electrical position indicator

*see information on working medium on page 2



Sectional drawing

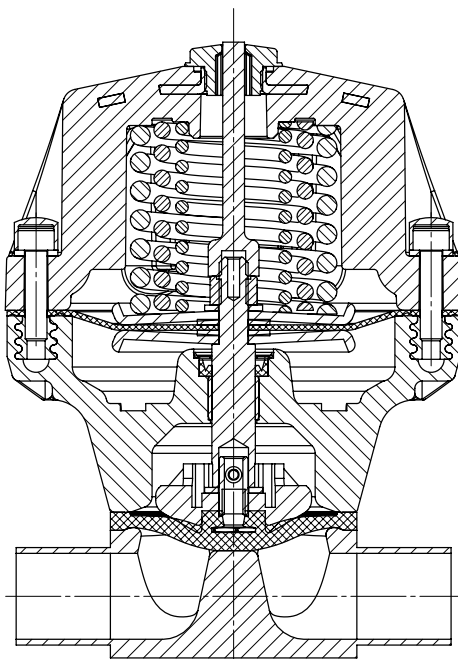

Technical data

Working medium

Corrosive, inert, gaseous and liquid media which have no negative impact on the physical and chemical properties of the body and diaphragm material.

The valve will seal in both flow directions up to full operating pressure. (All pressures are gauge pressures.)

Temperatures

Medium temperature -10 ... 80 °C

Ambient temperature 0 ... 60 °C

Control medium

Max. perm. temperature of control medium 40 °C

Filling volume

Actuator size	Control function 1	Control function 2
1/N	0,17 dm ³	0,11 dm ³
2/N	0,38 dm ³	0,23 dm ³
3/N	1,10 dm ³	0,54 dm ³

C.f. 3 = for filling volume in open position see c.f. 1, for filling volume in closed position see c.f. 2

		Operating pressure [bar]		Control pressure [bar]		
Diaphragm size	DN	EPDM / FPM	PTFE	Control function 1	Control function 2	Control function 3
25	15, 20, 25	0 - 10	0 - 6	5.5 - 7.0	max. 5.5	max. 5.5
40	32, 40	0 - 10	0 - 6	5.5 - 7.0	max. 5.5	max. 5.5
50	50, 65	0 - 10	0 - 6	5.5 - 7.0	max. 5.0	max. 5.0

All pressures are gauge pressures. Operating pressure values were determined with static operating pressure applied on one side of a closed valve. Sealing at the valve seat and atmospheric sealing is ensured for the given values. Information on operating pressures applied on both sides and for high purity media on request.

Kv values [m³/h]

Pipe standard	DIN	EN 10357 series B (formerly DIN 11850 series 1)	EN 10357 series A (formerly DIN 11850 series 2) / DIN 11866 series A	DIN 11850 Series 3	SMS 3008	ASME BPE / DIN 11866 series C	ISO 1127 / EN 10357 series C / DIN 11866 series B
Connection code	0	16	17	18	37	59	60
MG	DN						
25	15	4.1	4.7	4.7	4.7	-	7.4
	20	6.3	7.0	7.0	7.0	-	13.2
	25	13.9	15.0	15.0	15.0	12.6	16.2
40	32	25.3	27.0	27.0	27.0	26.2	30.0
	40	29.3	30.9	30.9	30.9	30.2	32.8
50	50	46.5	48.4	48.4	48.4	51.7	55.2
	65	-	-	-	-	62.2	61.8

MG = diaphragm size

Kv values determined acc. to DIN EN 60534, inlet pressure 5 bar, Δp 1 bar, stainless steel valve body (forged body) and soft elastomer diaphragm. The Kv values for other product configurations (e.g. other diaphragm or body materials) may differ. In general, all diaphragms are subject to the influences of pressure, temperature, the process and their tightening torques. Therefore the Kv values may exceed the tolerance limits of the standard.

Technical data

Control functions 2 + 3

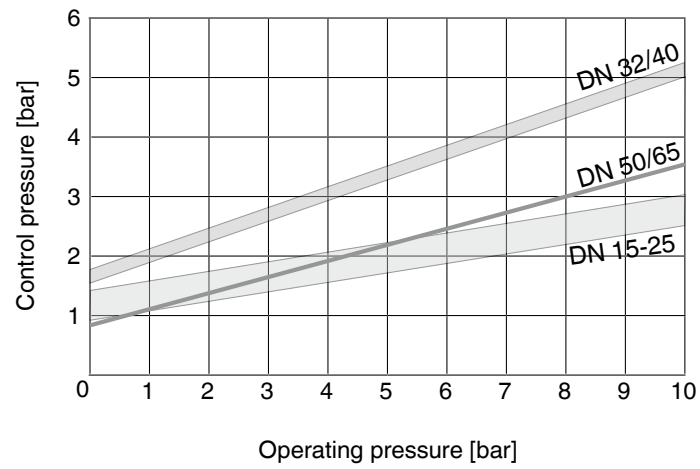

The values shown relate to control function 2 (with opening spring).
For control function 3 (without opening spring) control pressure is approx. 1 bar lower.

The control pressure depending on the prevailing operating pressure, as shown in the diagram, is intended as a guide for operating the system with low wear on the diaphragm.

Order data

Body configuration	Code
2/2-way body	D

Connection	Code
Butt weld spigots	
Spigots DIN	0
Spigots EN 10357 series B (formerly DIN 11850 series 1)	16
Spigot EN 10357 series A (formerly DIN 11850 series 2) / DIN 11866 series A	17
Spigots DIN 11850 series 3	18
Spigots JIS-G 3447	35
Spigots JIS-G 3459	36
Spigots SMS 3008	37
Spigots BS 4825 Part 1	55
Spigot ASME BPE / DIN 11866 series C	59
Spigot ISO 1127 / EN 10357 series C / DIN 11866 series B	60
Spigots ANSI/ASME B36.19M Schedule 10s	63
Spigots ANSI/ASME B36.19M Schedule 40s	65

Threaded connections	
Threaded sockets DIN ISO 228	1
Threaded sockets NPT	31
Threaded spigots DIN 11851	6
One side threaded spigot, other side cone spigot and union nut, DIN 11851	62
Aseptic unions on request	

Flanges	
Flanges EN 1092 / PN16 / form B, length EN 558, series 1, ISO 5752, basic series 1	8
Flanges ANSI Class 150 RF, length MSS SP-88	38
Flanges ANSI Class 125/150 RF, length EN 558, series 1, ISO 5752, basic series 1	39

Clamp connections	
Clamps ASME BPE for pipe ASME BPE, length ASME BPE	80
Clamps DIN 32676 series B for pipe EN ISO 1127, length EN 558, series 7	82
Clamps ASME BPE for pipe ASME BPE, length EN 558, series 7	88
Clamps DIN 32676 series A for pipe DIN 11850, length EN 558, series 7	8A
Clamps SMS 3017 for pipe SMS 3008, length EN 558, series 7	8E
Aseptic clamps on request	

For overview of available valve bodies see page 13

Valve body material	Code
EN-GJL-250, (GG 25) (Cast iron)	8
EN-GJS-400-18-LT (S.G. Iron 40.3), PFA lined	17
EN-GJS-400-18-LT (S.G. Iron 40.3), PP lined	18
1.4435, investment casting	C3
1.4408, investment casting	37
1.4408, PFA lined	39
1.4435 (316L), forged body	40
1.4435 (BN2), forged body $\Delta Fe < 0.5\%$	42
EN-GJS-400-18-LT (S.G. Iron 40.3), hard rubber lined	83
1.4539, forged body	F4

Diaphragm material	Code
NBR	2
FPM	4
EPDM	13
EPDM	14
EPDM	17
EPDM	36
PTFE/EPDM convex, PTFE loose	5E
PTFE/EPDM, PTFE lamin.	52
Material complies with FDA requirements, except codes 2, 4 and 14	
The combination of PFA lining with 5E diaphragms is only conditionally suitable for gaseous media. If low seat leakage rates are required for gaseous media, other combinations are preferable.	

Control function	Code
Normally closed (NC)	1
Normally open (NO)	2
Double acting (DA)	3

Actuator size	Code
Diaphragm size 25	1/N
Diaphragm size 40	2/N
Diaphragm size 50	3/N

Order data

Internal surface finishes for forged and block material bodies ¹

Readings for Process Contact Surfaces	Mechanically polished ²		Electropolished	
	Hygienic class DIN 11866	Code	Hygienic class DIN 11866	Code
Ra ≤ 0.80 μm	H3	1502	HE3	1503
Ra ≤ 0.60 μm	-	1507	-	1508
Ra ≤ 0.40 μm	H4	1536	HE4	1537
Ra ≤ 0.25 μm ³	H5	1527	HE5	1516

Readings for Process Contact Surfaces acc. to ASME BPE 2016 ⁴	Mechanically polished ²		Electropolished	
	ASME BPE Surface Designation	Code	ASME BPE Surface Designation	Code
Ra Max. = 0.76 μm (30 μinch)	SF3	SF3	-	-
Ra Max. = 0.64 μm (25 μinch)	SF2	SF2	SF6	SF6
Ra Max. = 0.51 μm (20 μinch)	SF1	SF1	SF5	SF5
Ra Max. = 0.38 μm (15 μinch)	-	-	SF4	SF4

Internal surface finishes for investment cast bodies

Readings for Process Contact Surfaces	Mechanically polished ²	
	Hygienic class DIN 11866	Code
Ra ≤ 6.30 μm	-	1500
Ra ≤ 0.80 μm	H3	1502
Ra ≤ 0.60 μm ⁵	-	1507

¹ Surface finishes of customized valve bodies may be limited in special cases.

² Or any other finishing method that meets the Ra value (acc. to ASME BPE).

³ The smallest possible Ra finish for pipe connections with an internal pipe diameter < 6 mm is 0.38 μm.

⁴ When using these surfaces, the bodies are marked according to the specifications of ASME BPE.

The surfaces are only available for valve bodies which are made of materials (e.g. GEMÜ material codes 40, 41, F4, 44) and use connections (e.g. GEMÜ connection codes 59, 80, 88) according to ASME BPE.

⁵ Not possible for GEMÜ connection code 59, DN 8 and GEMÜ connection code 0, DN 4.

Ra acc. to DIN EN ISO 4288 and ASME B46.1

Order example	695	25	D	60	C3	17	1	1/N	1500
Type	695								
Nominal size		25							
Body configuration (code)			D						
Connection (code)				60					
Valve body material (code)					C3				
Diaphragm material (code)						17			
Control function (code)							1		
Actuator size (code)								1/N	
Surface finish (code)									1500

Actuator dimensions [mm]

Control function 1

MG	DN	ø B	A	A1	G	Weight [kg]
25	15 - 25	125	145	47	G 1/4	1,5
40	32 - 40	155	194	75	G 1/4	3,0
50	50 - 65	210	240	90	G 1/4	5,5

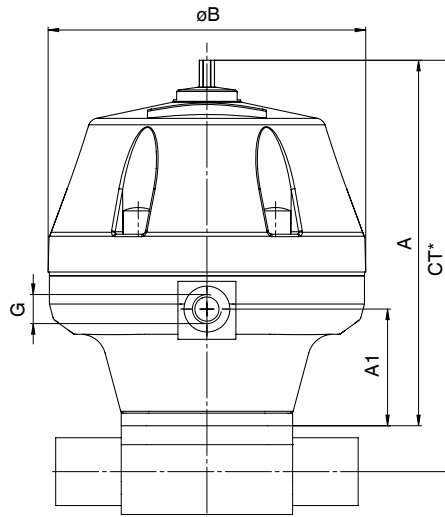

* CT = A + H1 (see body dimensions)

Control function 2 + 3

MG	DN	ø B	A	A1	A2	G	Weight [kg]
25	15 - 25	125	98	47	27	G 1/4	1,0
40	32 - 40	155	135	75	27	G 1/4	2,1
50	50 - 65	210	164	90	29	G 1/4	3,6

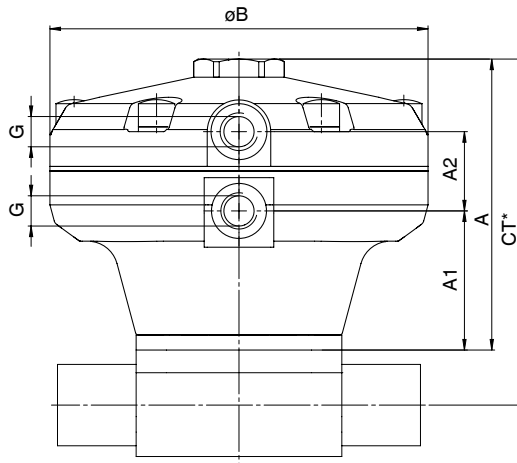

* CT = A + H1 (see body dimensions)

Body dimensions [mm]

Butt weld spigots, connection code 0, 16, 17, 18 Valve body material: Investment casting (code C3), forged body (code 40, F4)

Pipe standard							DIN		EN 10357 series B (formerly DIN 11850 series 1)		EN 10357 series A (formerly DIN 11850 series 2) / DIN 11866 series A		DIN 11850 Series 3		Weight [kg]
Connection code							0		16		17		18		
MG	DN	NPS	L	c	H1*	H1**	ød	s	ød	s	ød	s	ød	s	
25	15	1/2"	120	25	13.0	19.0	18	1.5	18	1.0	19	1.5	20	2.0	0.62
	20	3/4"	120	25	16.0	19.0	22	1.5	22	1.0	23	1.5	24	2.0	0.58
	25	1"	120	25	19.0	19.0	28	1.5	28	1.0	29	1.5	30	2.0	0.55
40	32	1 1/4"	153	25	24.0	26.0	34	1.5	34	1.0	35	1.5	36	2.0	1.45
	40	1 1/2"	153	25	26.0	26.0	40	1.5	40	1.0	41	1.5	42	2.0	1.32
50	50	2"	173	30	32.0	32.0	52	1.5	52	1.0	53	1.5	54	2.0	2.25

* only for investment cast design ** only for forged design MG = diaphragm size
For materials see overview on page 13

Butt weld spigots, connection code 60 Valve body material: Investment casting (code C3), forged body (code 40, F4)

Pipe standard							ISO 1127 / EN 10357 series C / DIN 11866 series B		Weight [kg]
Connection code							60		
MG	DN	NPS	L	c	H1*	H1**	ød	s	
25	15	1/2"	120	25	13.0	19.0	21.3	1.6	0.62
	20	3/4"	120	25	16.0	19.0	26.9	1.6	0.58
	25	1"	120	25	19.0	19.0	33.7	2.0	0.55
40	32	1 1/4"	153	25	24.0	26.0	42.4	2.0	1.45
	40	1 1/2"	153	25	26.0	26.0	48.3	2.0	1.32
50	50	2"	173	30	32.0	32.0	60.3	2.0	2.25

* only for investment cast design ** only for forged design MG = diaphragm size
For materials see overview on page 13

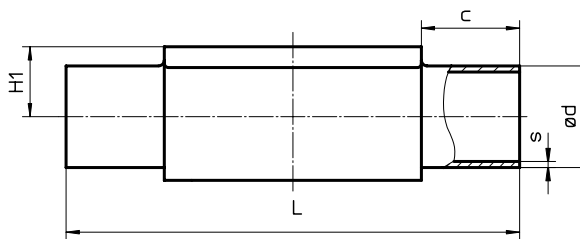

Body dimensions [mm]

Butt weld spigots, connection code 35, 36, 37 Valve body material: Investment casting (code C3), forged body (code 40, F4)

Pipe standard							JIS-G 3447		JIS-G 3459		SMS 3008		Weight [kg]
Connection code							35		36		37		
MG	DN	NPS	L	c	H1*	H1**	ød	s	ød	s	ød	s	
25	15	1/2"	120	25	-	19.0	-	-	21.7	2.10	-	-	0.62
	20	3/4"	120	25	-	19.0	-	-	27.2	2.10	-	-	0.58
	25	1"	120	25	19.0	19.0	25.4	1.2	34.0	2.80	25.0	1.2	0.55
40	32	1 1/4"	153	25	-	26.0	31.8	1.2	42.7	2.80	33.7	1.2	1.45
	40	1 1/2"	153	25	26.0	26.0	38.1	1.2	48.6	2.80	38.0	1.2	1.32
50	50	2"	173	30	32.0	32.0	50.8	1.5	60.5	2.80	51.0	1.2	2.25
	65	2 1/2"	173	30	-	34.0	63.5	2.0	-	-	63.5	1.6	2.20

* only for investment cast design ** only for forged design MG = diaphragm size
For materials see overview on page 13

Butt weld spigots, connection code 55, 59, 63, 65 Valve body material: Investment casting (code C3), forged body (code 40, F4)

Pipe standard							BS 4825 Part 1		ASME BPE / DIN 11866 series C		ANSI/ASME B36.19M Schedule 10s		ANSI/ASME B36.19M Schedule 40s		Weight [kg]
Connection code							55		59		63		65		
MG	DN	NPS	L	c	H1*	H1**	ød	s	ød	s	ød	s	ød	s	
25	15	1/2"	120	25	-	19.0	-	-	-	-	21.3	2.11	21.3	2.77	0.62
	20	3/4"	120	25	16.0	19.0	19.05	1.2	19.05	1.65	26.7	2.11	26.7	2.87	0.58
	25	1"	120	25	19.0	19.0	-	-	25.40	1.65	33.4	2.77	33.4	3.38	0.55
40	32	1 1/4"	153	25	-	26.0	-	-	-	-	42.2	2.77	42.2	3.56	1.45
	40	1 1/2"	153	25	26.0	26.0	-	-	38.10	1.65	48.3	2.77	48.3	3.68	1.32
50	50	2"	173	30	32.0	32.0	-	-	50.80	1.65	60.3	2.77	60.3	3.91	2.25
	65	2 1/2"	173	30	-	34.0	-	-	63.50	1.65	-	-	-	-	2.10

* only for investment cast design ** only for forged design MG = diaphragm size
For materials see overview on page 13

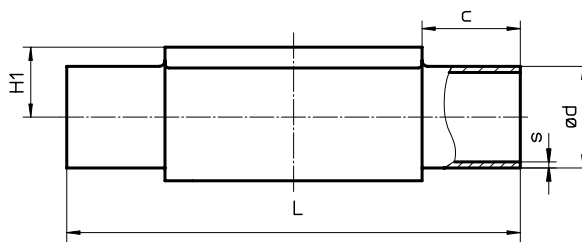

Body dimensions [mm]

Threaded sockets, connection code 1 Valve body material: GG 25 (code 8), investment casting (code 37)

MG	DN	R	L	Material code 8					Material code 37					Weight [kg]
				H	H1	t	SW2	Number of flats	H	H1	t	SW2	Number of flats	
25	15	G 1/2	85	35	19	12	32	6	29	16	15	27	6	0.32
	20	G 3/4	85	40	19	13	41	6	32	16	16	32	6	0.34
	25	G 1	110	42	19	16	46	6	37	16	13	41	6	0.39
40	32	G 1 1/4	120	56	28	16	55	6	49	24	20	50	8	0.88
	40	G 1 1/2	140	61	28	18	65	6	52	24	18	55	8	0.93
50	50	G 2	165	73	35	18	75	6	68	33	26	70	8	1.56

MG = diaphragm size

For materials see overview on page 13

Threaded sockets, connection code 31 Valve body material: Investment casting (code 37)

MG	DN	R	L	H	H1	t	SW2	Number of flats	Weight [kg]
25	15	NPT 1/2	85	29	16	14	27	6	0.32
	20	NPT 3/4	85	32	16	14	32	6	0.34
	25	NPT 1	110	42	21	17	41	6	0.39
40	32	NPT 1 1/4	120	49	24	17	50	8	0.88
	40	NPT 1 1/2	140	52	24	17	55	8	0.93
50	50	NPT 2	165	68	33	18	70	8	1.56

MG = diaphragm size

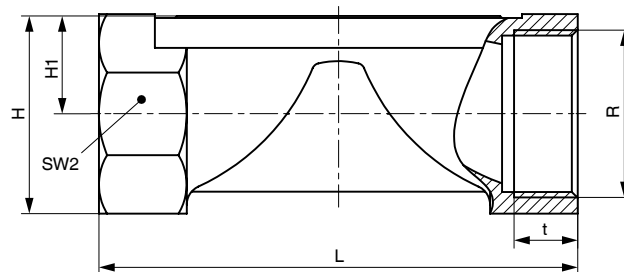

Body dimensions [mm]

Threaded connections, connection code 6, 62 Valve body material: Forged body (code 40)

MG	DN	H1	ød1	Thread to DIN 405 R	Code 6 L	Code 62 L	Weight [kg]
25	15	19	16,0	RD 34 x 1/8	118	116	0,71
	20	19	20,0	RD 44 x 1/6	118	114	0,78
	25	19	26,0	RD 52 x 1/6	128	127	0,79
40	32	26	32,0	RD 58 x 1/6	147	147	1,66
	40	26	38,0	RD 65 x 1/6	160	160	1,62
50	50	32	50,0	RD 78 x 1/6	191	191	2,70

MG = diaphragm size

Code 6

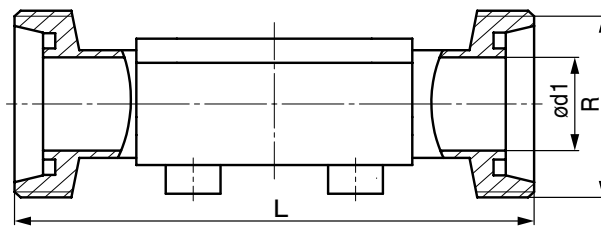

Code 62

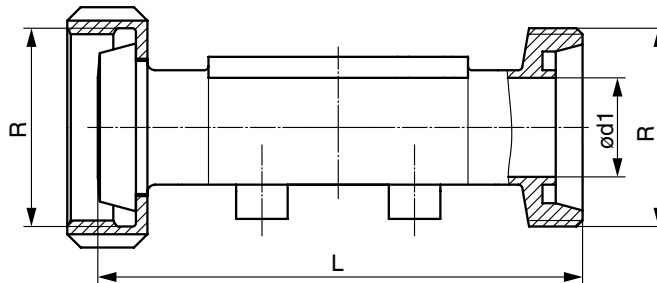

Body dimensions [mm]

Flanges - DIN EN 1092, connection code 8
 Valve body material GG 25 (code 8), GGG 40.3 (code 17, 18, 83), investment casting (code C3),
 forged body (code 40), investment casting PFA lined (code 39)

MG	DN	øD	øk	øL	Number of bolts	H1				FTF	Weight [kg]
						Material code 8	Material code 17, 18, 39, 83	Material code C3	Material code 40		
25	15	95	65	14	4	19.0	18.0	13.0	19.0	130*	1.85
	20	105	75	14	4	19.0	20.5	16.0	19.0	150	2.35
	25	115	85	14	4	19.0	23.0	19.0	19.0	160	2.85
40	32	140	100	19	4	28.0	28.7	24.0	26.0	180	4.90
	40	150	110	19	4	28.0	33.0	26.0	26.0	200	5.65
50	50	165	125	19	4	35.0	39.0	32.0	32.0	230	7.45

*Material code C3, 40 FTF = 150 (no DIN length)

MG = diaphragm size

For materials see overview on page 13

Flanges - ANSI Class 125/150 RF, connection code 38, 39
 Valve body material GG 25 (code 8), GGG 40.3 (code 17, 18, 83), investment casting (code C3),
 forged body (code 40), investment casting PFA lined (code 39)

MG	DN	øD	øk	øL	Number of bolts	H1				FTF		Weight [kg]	
						Connection code 38, 39				MSS Sp-88 Connection code 38			EN 558 Series 1 Connection code 39
						Material code 8	Material code 17, 18, 39, 83	Material code C3	Material code 40	Material code 17, 18, 39, 83			Material code 8, 17, 18, C3, 39, 40, 83
25	15	90	60.3	15.9	4	19.0	18.0	13.0	19.0	-	-	130	1.85
	20	100	69.9	15.9	4	19.0	20.5	16.0	19.0	146	146.4	150	2.35
	25	110	79.4	15.9	4	19.0	23.0	19.0	19.0	146	146.4	160	2.85
40	32	115	88.9	15.9	4	28.0	28.7	24.0	26.0	-	-	180	4.90
	40	125	98.4	15.9	4	28.0	33.0	26.0	26.0	175	171.4	200	5.65
50	50	150	120.7	19.0	4	35.0	39.0	32.0	32.0	200	197.4	230	7.45

MG = diaphragm size

For materials see overview on page 13

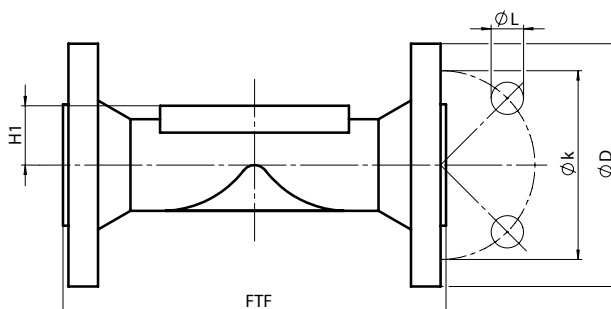

Body dimensions [mm]

Clamp connections, connection code 80, 82, 88, 8A, 8E Valve body material: Forged body (code 40, F4)

Pipe connection for clamp			ASME BPE						ISO 1127 / EN 10357 series C / DIN 11866 series B			EN 10357 series A (formerly DIN 11850 series 2) / DIN 11866 series A			SMS 3008			Weight [kg]	
Clamp connection			ASME BPE						DIN 32676 series B			DIN 32676 series A			ISO 2852 / SMS 3017				
Clamp connection code			80			88			82			8A			8E				
MG	DN	NPS	H1	ød1	ød3	L	ød1	ød3	L	ød1	ød3	L	ød1	ød3	L	ød1	ød3		L
25	15	1/2"	19.0	-	-	-	-	-	-	18.1	50.5	108.0	16	34.0	108.0	-	-	-	0.75
	20	3/4"	19.0	15.75	25.0	101.6	15.75	25.0	117	23.7	50.5	117.0	20	34.0	117.0	-	-	-	0.71
	25	1"	19.0	22.10	50.5	114.3	22.10	50.5	127	29.7	50.5	127.0	26	50.5	127.0	22.6	50.5	127	0.63
40	32	1 1/4"	26.0	-	-	-	-	-	-	38.4	64.0	146.0	32	50.5	146.0	31.3	50.5	146	1.62
	40	1 1/2"	26.0	34.80	50.5	139.7	34.80	50.5	159	44.3	64.0	159.0	38	50.5	159.0	35.6	50.5	159	1.50
50	50	2"	32.0	47.50	64.0	158.8	47.50	64.0	190	56.3	77.5	190.0	50	64.0	190.0	48.6	64.0	190	2.50
	65	2 1/2"	34.0	60.20	77.5	193.8	60.20	77.5	216	-	-	-	-	-	-	60.3	77.5	216	2.30

MG = diaphragm size

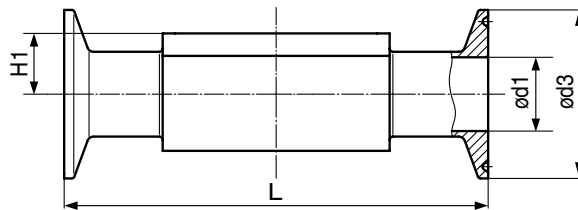

Overview of valve bodies for GEMÜ 695																	
		Spigots															
Connection code		0	16	17		18	35	36	37		55	59		60		63	65
Material code		40	40	C3	40	40	40	40	C3	40	40	C3	40	C3	40	40	40
MG	DN																
25	15	X	X	X	X	X	-	X	-	-	-	-	-	X	X	X	X
	20	X	X	X	X	X	-	X	-	-	X	X	X	X	X	X	X
	25	X	X	X	X	X	X	X	X	X	-	X	X	X	X	X	X
40	32	X	X	X	X	X	X	X	X	-	X	-	-	X	X	X	X
	40	X	X	X	X	X	X	X	X	X	-	X	X	X	X	X	X
50	50	X	X	X	X	X	X	X	X	X	-	X	X	X	X	X	X
	65	-	-	-	-	-	X	-	-	X	-	-	X	-	-	-	-

Availability of material code 42, F4: same as code 40
MG = diaphragm size

All rights including copyright and industrial property rights are expressly reserved.

Overview of valve bodies for GEMÜ 695																													
		Threaded connections				Clamps					Flanges																		
Connection code		1	31	6	62	80	82	88	8A	8E	8							38				39							
Material code		8	37	37	40	40	40	40	40	40	8	17	18	C3	39	40	83	17	18	39	83	8	17	18	C3	39	40	83	
MG	DN																												
25	15	X	X	X	W	W	-	W	-	K	-	X*	X	X	W	X	W	X	-	-	-	-	X*	X	X	W	X	W	X*
	20	X	X	X	W	W	K	K	K	K	-	X*	X	X	W	X	W	X	X	X**	X	X*	X*	X	X	W	X	W	X*
	25	X	X	X	W	W	K	K	K	K	K	X*	X	X	W	X	W	X	X	X**	X	X*	X*	X	X	W	X	W	X*
40	32	X	X	X	W	W	-	W	-	K	K	X*	X	X	W	X	W	X	-	-	-	-	X*	X	X	W	X	W	X*
	40	X	X	X	W	W	K	W	K	K	K	X*	X	X	W	X	W	X	X	X**	X	X*	X*	X	X	W	X	W	X*
50	50	X	X	X	W	W	K	W	K	K	K	X*	X	X	W	X	W	X	X	X**	X	X*	X*	X	X	W	X	W	X*
	65	-	-	-	-	-	W	-	W	-	W	-	-	-	-	-	-	-	-	-	-	-	-	-	-	-	-	-	-

* Valve bodies are not suitable for use with diaphragms code 5E.
** Connection code 38 / material code 18 on request
X = Standard
K = Connections completely machined (not welded)
W = Welded construction
Availability of material code 42, F4: same as code 40
MG = diaphragm size

Should there be any doubts or misunderstandings, the German version of this data sheet is the authoritative document!

For further metal diaphragm valves, accessories and other products, please see our Product Range catalogue and Price List.
Contact GEMÜ.

GEMÜ® VALVES, MEASUREMENT AND CONTROL SYSTEMS

