

CARBON STEEL Y STRAINER PN 40



ISO 9001 : 2015



PED 2014/68/EU



Certificate 3.1

Size : DN 15 to DN 300
Ends : Flanged R.F. PN25/40
Min Temperature : - 29°C
Max Temperature : + 425°C
Max Pressure : 40 Bars
Specifications : Stainless steel removable filter
Bolted bonnet with draining cap

Materials : Carbon steel ASTM A216 WCB

CARBON STEEL Y STRAINER PN 40

SPECIFICATIONS :

- Removable stainless steel filter
- R.F. Flanged PN25/40 , PN40 from DN200 to 300
- Horizontal or vertical position with descendant fluid (respect the flow direction indicated by the arrow)
- Mesh 1mm up to DN 50 , 1.25 mm from DN 65 to 80, 1.6 mm from DN100 to 200, 4 mm over
- Bolted bonnet with draining cap threaded BSP
- Blue painting RAL 5002, 80 µm thickness

USE :

- For all common fluids
- Min Temperature Ts : - 29°C
- Max Temperature Ts :+ 425°C
- Max Pressure Ps : 40 bars (see graph)

PRESSURE / TEMPERATURE RELATION (STEAM EXCLUDED) :

Temperature (°C)	-29	-10	120	200	250	300	350	400	425
Pressure (Bar)	25.8	40	40	34.7	31.4	28	24	21	18

FLOW COEFFICIENT Kvs (M3 / h) :

DN	15	20	25	32	40	50	65	80	100	125	150	200	250	300
Kvs (m3/h)	6.2	10.8	16.8	26.1	36.7	61	98.6	146	234	376	405	752	1220	1865

CARBON STEEL Y STRAINER PN 40

HEAD LOSS :

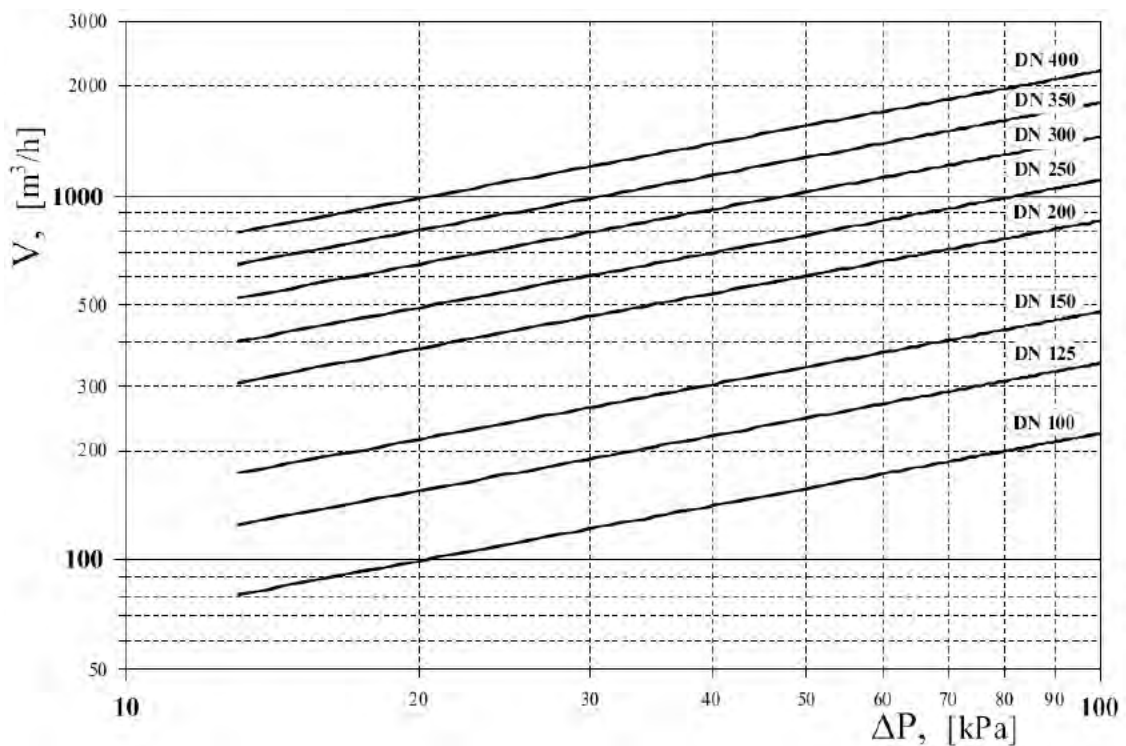
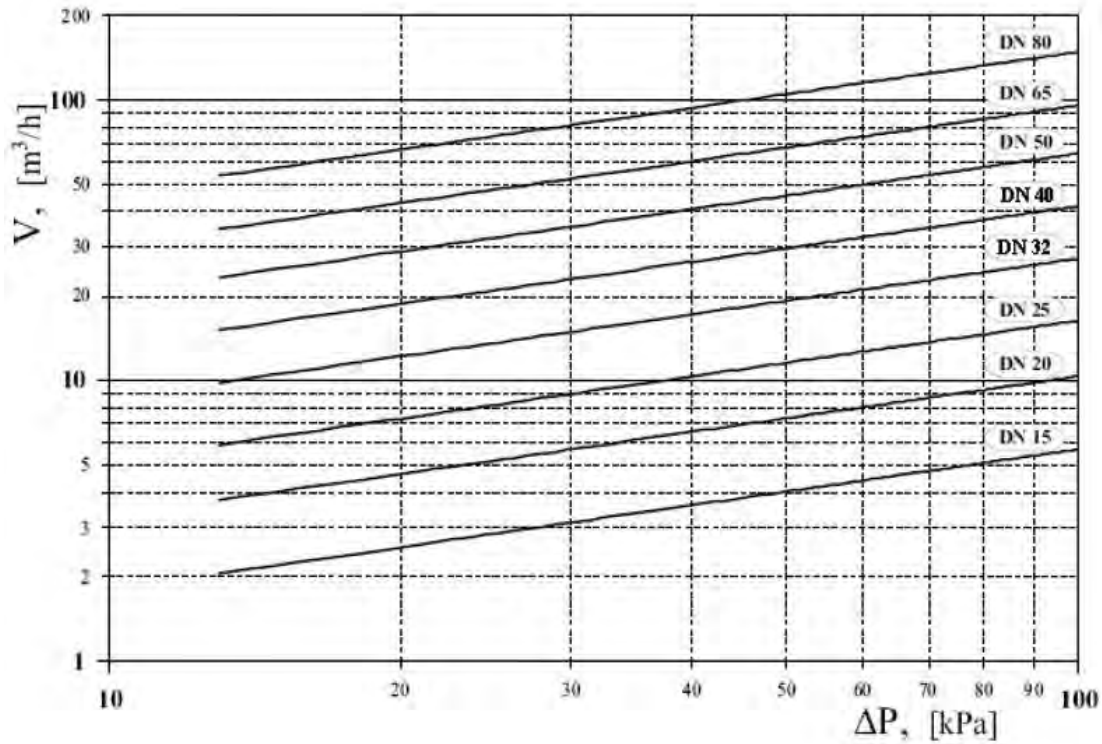

CARBON STEEL Y STRAINER PN 40
RANGE :

- Carbon steel flanged R. F. PN25/40 DN 15 up to DN 150 and PN40 from DN200 to DN300 **Ref.235**
- Carbon steel flanged male-female facing PN25/40 from DN 15 up to DN 80 **Ref.2353**

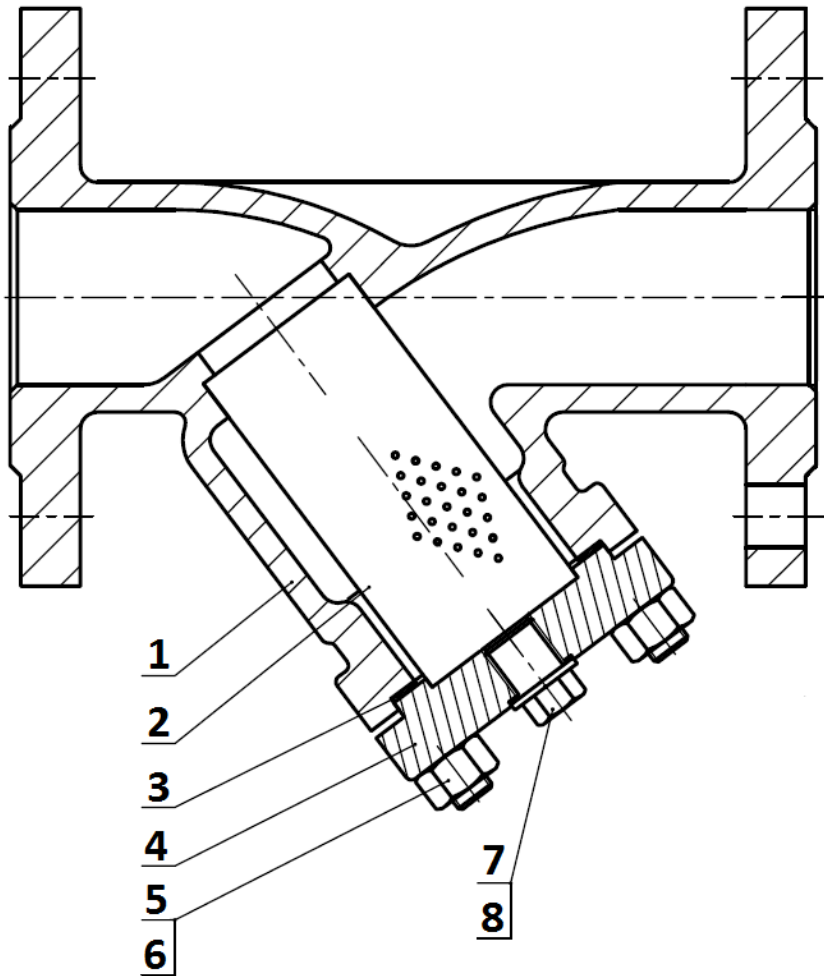
MATERIALS :

Item	Designation	Materials
1	Body	ASTM A 216 WCB
2	Filter	AISI 304
3	Bonnet gasket	Graphite + AISI 304
4	Bonnet	ASTM A216 WCB
5	Stud	A193-B7
6	Nut	A194-2H
7	Plug	A105
8	Plug gasket	Graphite + AISI 304

CARBON STEEL Y STRAINER PN 40

SIZE (in mm) :

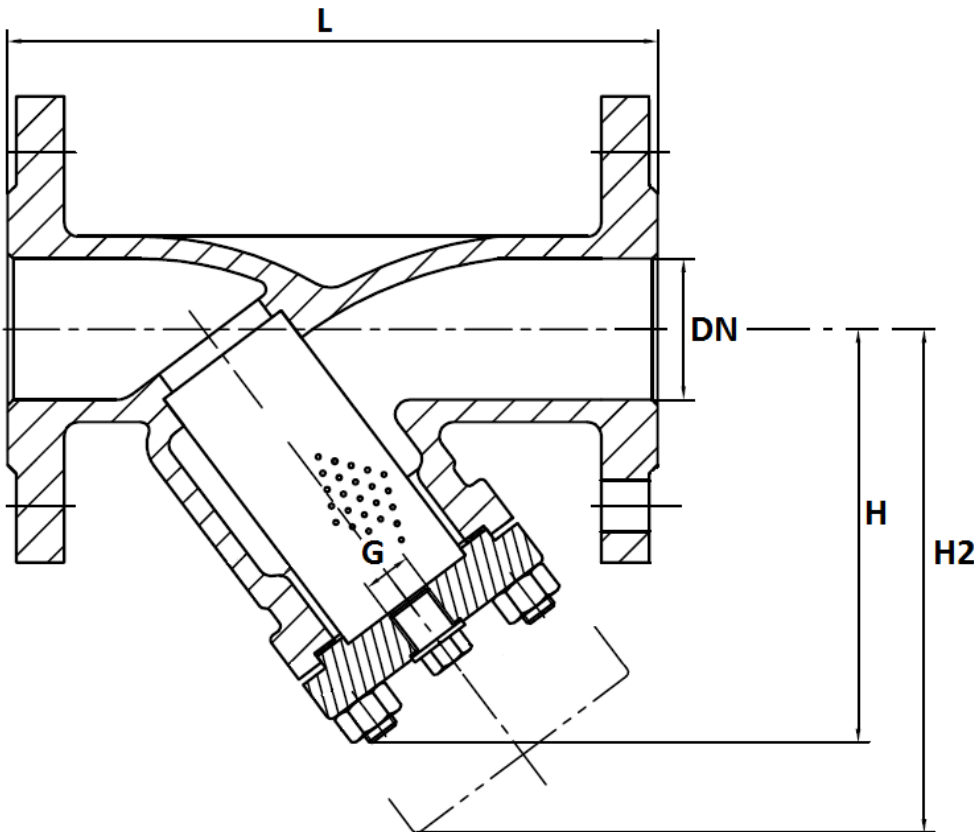

Filter size :

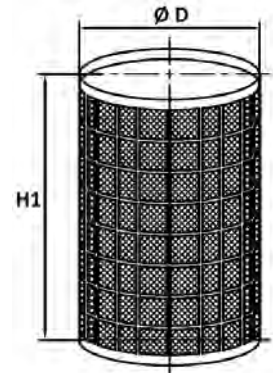

Gasket size :

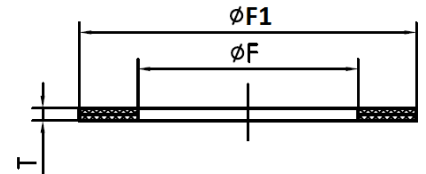

Ref.	DN	15	20	25	32	40	50	65	80	100	125	150	200	250	300
235	L	130	150	160	180	200	230	290	310	350	400	480	600	730	850
	H	98	97	108	113	138	147	170	204	240	288	334	380	535	640
	H2	106	115	122	130	155	165	190	225	265	310	360	427	590	710
	G (drain BSP)	3/8"	3/8"	3/4"	3/4"	1"	1"	1"	1"	1 1/2"	1 1/2"	1 1/2"	1 1/2"	2"	2"
	Ø D	22	22	29	35	42	52	58	75	104	124	150	190	243	295
	H1	48	59	75	85	97	105	121	150	175	205	240	310	390	458
	Mesh	1	1	1	1	1	1	1.25	1.25	1.6	1.6	1.6	1.6	4	4
	Ø F1	50	50	56	56	75	75	92	106	135	170	195	250	335	385
	Ø F	40	40	44	44	60	60	75	92	116	150	165	220	295	345
	T	1.5	1.5	1.5	1.5	1.5	1.5	1.5	1.5	1.5	1.5	1.5	1.5	1.5	1.5
	Weight (Kg)	2.8	3.4	4.9	6.6	8.9	11.3	15.8	20.6	32.1	47.9	66	135	201	317

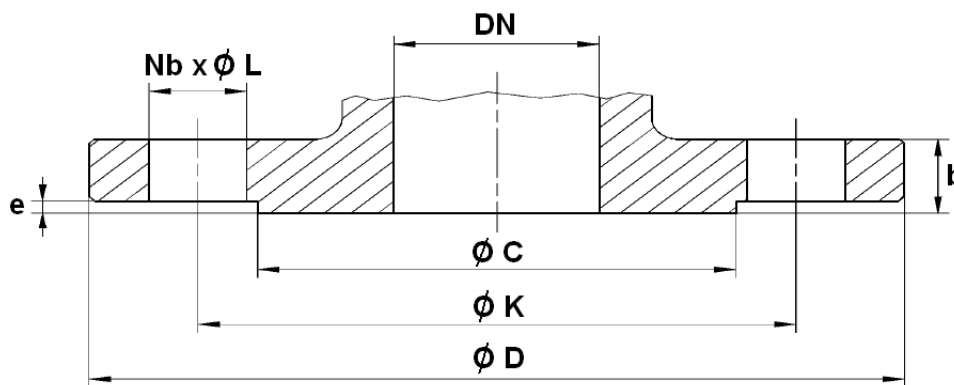
CARBON STEEL Y STRAINER PN 40
FLANGES SIZE (in mm) :

DN	15	20	25	32	40	50	65	80	100	125	150	200	250	300
Ø C	45	58	68	78	88	102	122	138	162	188	218	285	345	410
Ø D	95	105	115	140	150	165	185	200	235	270	300	375	450	515
Ø K	65	75	85	100	110	125	145	160	190	220	250	320	385	450
Nb x Ø L	4 x 14	4 x 14	4 x 14	4 x 18	4 x 18	4 x 18	8 x 18	8 x 18	8 x 22	8 x 26	8 x 26	12 x 30	12 x 33	16 x 33
b	16	18	18	18	18	20	22	24	24	26	28	34	38	42
e	2	2	2	2	3	3	3	3	3	3	3	3	3	4

CARBON STEEL Y STRAINER PN 40

STANDARDS :

- Fabrication according to ISO 9001 : 2015 and ISO 14001 :2015
- Design according to DIN 3356
- DIRECTIVE 2014/68/EU : CE N° 0036
Risk Category III Module H
- Certificate 3.1 on request
- Tests according to DIN 3230
- Length according to EN 558 series 1 (DIN 3202-1 F1 – NF 29354)
- Flanges R.F. according to EN 1092-1 PN40

INSTALLATION POSITIONS :

Vertical position (descendand fluid)



Horizontal position

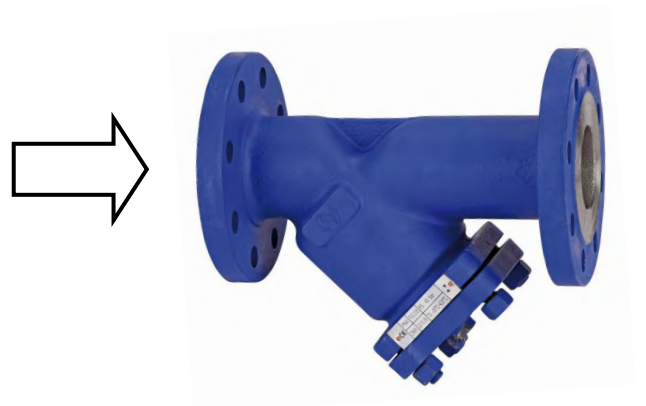

ADVICE : Our opinion and our advice are not guaranteed and SFERACO shall not be liable for the consequences of damages.
The customer must check the right choice of the products with the real service conditions.

CARBON STEEL Y STRAINER PN 40**INSTALLATION INSTRUCTIONS****GENERAL GUIDELINES :**

- Ensure that the strainers to be used are appropriate for the conditions of the installation (type of fluid, pressure and temperature).
- Be sure to have enough valves to be able to isolate the sections of piping as well as the appropriate equipment for maintenance and repair.
- Ensure that the strainers to be installed are of correct strength to be able to support the capacity of their usage.
- **Installation of all circuits should ensure that their function can be automatically tested on a regular basis (at least two times a year).**

INSTALLATION INSTRUCTIONS :

- **Before installing the strainers, clean and remove any objects from the pipes** (in particular bits of sealing and metal) which could obstruct and block the strainers.
- **Ensure that both connecting pipes either side of the strainer (upstream and downstream) are aligned (if they're not, the strainer may not work correctly).**
- **Make sure that the two sections of the pipe (upstream and downstream) match, the strainer unit will not absorb any gaps. Any distortions in the pipes may affect the tightness of the connection, the working of the strainer and can even cause a rupture.** To be sure, place the kit in position to ensure the assembling will work.
- Make sure flanges are cleaned.
- **If sections of piping do not have their final support in place, they should be temporarily fixed. This is to avoid unnecessary strain on the strainer.**
- Tighten the bolts in cross.
- The pressurisation must be increased gradually.
- So that the maintenance operations could be easily done, place a stop valve before and after the strainer. Thereby, the strainer could be isolated. During this operation, ensure to have a new bonnet gasket to avoid a leakage during the restarting.
- **Fluids in the strainer must not contain solid objects (it could damaged the seat).**